

OCEANTECH

Aquatic Products & Technologies

Tank Units | Protein Skimmers | Compact Filter Units
Drum Filters | Filtration Equipments



CONTENTS



Crafting aquatic ecosystems with care.

- 3 who we are
- 9 what we offer
- 11 OCEANTECH™
- 15 our solution partners
- 17 product range
- 19 compact filter units
- 23 drum filters
- 27 protein skimmers
- 35 filtration equipments
- 55 tank units
- 63 references
- 75 become a client

Aquatic Design Engineering Construction

About ADEC

ADEC is one of the world's leading companies in the construction of **public aquariums** worldwide, and has implemented many **large-scale turnkey projects** to date.

Using its expertise in filtration systems and **thermoplastic production** capability, ADEC has become a major supplier in recent years by producing **turnkey hatchery installations, closed circuit filtration systems, holding tanks** and **RAS** (Recirculating Aquaculture Systems) equip-

ment for Europe's largest companies operating in **aquaculture industry**.

ADEC employs experienced **design, construction** and **husbandry** staff that take projects from concept to completion. Many of our staff are industry professionals and leaders who are working as designers, aquaculture engineers, marine biologists, architects, interior designers, zoologists, aquarists, mechanical engineers, electrical engineers, artists and sculptors.





Adec provides comprehensive services for the aquaculture industry by offering expertise in **production planning, construction** and **project management** to ensure optimal outcomes for your aquaculture projects.

We specialise in fingerling and market-size fish production while providing a comprehensive Recirculating Aquaculture System (RAS) solution for fish production. From

the initial project inception we collaborate closely with our customers to understand your specific requirements by determining the optimal target fish species based on your geographical location and environmental conditions.

With this knowledge in hand our expert team creates a detailed engineering and technology blueprint which is tailored precisely to suit your needs.



**We are here for
all your aquatic projects.**



 Our Team Members 150+	 Date of Foundation 2017	 Number of Countries We Export 10+	 Production Area (m ²) 4.600	 Number of Facilities 3
--	--	--	---	---

Our Facilities

 Istanbul



ADEC Tuzla Factory

Total Area: 2200 m²
Production Capacity: 1400 units/year
Processing Capacity: 250.000 kg PP/ HDPE / PVC
Team: More than 55 experts including product designers, engineers, architects, plumbers, technicians and other employees.

 Muğla



ADEC Milas Factory

Total Area: 2400 m²
Processing Capacity: 200.000 kg PP/ HDPE / PVC
Team: More than 20 experts including product designers, engineers, architects, plumbers, technicians and other employees.

 Muğla

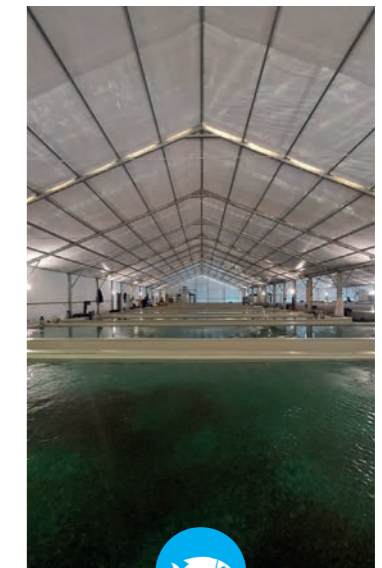

ADEC Milas Aquaculture Facility

Turkiye's first and only closed-circuit hatchery, nursery, and adaptation facility
Total Production Capacity: 80 tons/years & 39 million juvenile fish per year
Team: 28 experts including biologists, engineers, technicians, quality control and other employees.

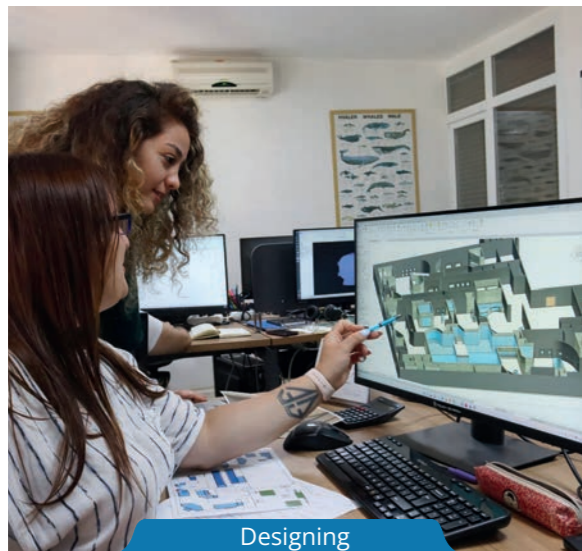

Designing



Engineering



Manufacturing



Construction

Production Planning

Fingerling & Grow out

At ADEC, we specialize in strategic production planning services for both fingerling and grow-out stages in the aquaculture sector. Our expertise ensures optimized production schedules and resource allocation, leading to increased efficiency and profitability for our customers.



Facility Design

Hatchery & RAS

With a focus on innovation and sustainability our expert team designs state-of-the-art facilities for hatcheries and recirculating aquaculture systems (RAS). From the initial broodstock units to final stage of grow-out areas we create healthy environments that promote fish growth and easy transitions between different stages of fish development.

RAS Design & Engineering

Complete Recirculation Filtration Systems

Our comprehensive recirculation filtration systems are carefully designed and engineered to maintain optimal water quality and ensure efficient waste management. We include sustainability in our design and provide cutting-edge solutions for RAS implementation.



Supply

Husbandry Tanks & RAS & Husbandry Equipment & Automation and Control Panels

As a one-stop solution provider we offer a wide range of aquaculture supplies including husbandry tanks, RAS components, aquaculture equipment and automation control panels. Our premium products ensure high performance and reliability.

Installation & Commissioning

RAS & Automation and Control Panels

Our experienced team handles the seamless installation and commissioning of RAS systems which include all the electrical system automation and control panels. Our systems ensure that your facility is set up efficiently and on time and budget.



Construction & Project Management

Hatchery & Nursery/Weaning & RAS grow out facility

From initial concept to completion we take charge of the entire construction and project management process. Whether it's a hatchery, nursery/weaning facility or RAS grow-out unit our turnkey solutions and ready for delivery approach ensures a timely and successful handover to our clients.



OCEANTECH™, an esteemed ADEC brand, is dedicated to delivering dependable LSS (Life Support Systems) products with **minimal maintenance** and **energy consumption**, tailored for **aquaculture facilities** worldwide.



GLOBAL FILTRATION BRAND

Our cutting-edge designs and equipment are designed to support the entire life cycle of aquatic farm animals, ranging from larvae hatcheries to Recirculating Aquaculture System (RAS) filtration systems.

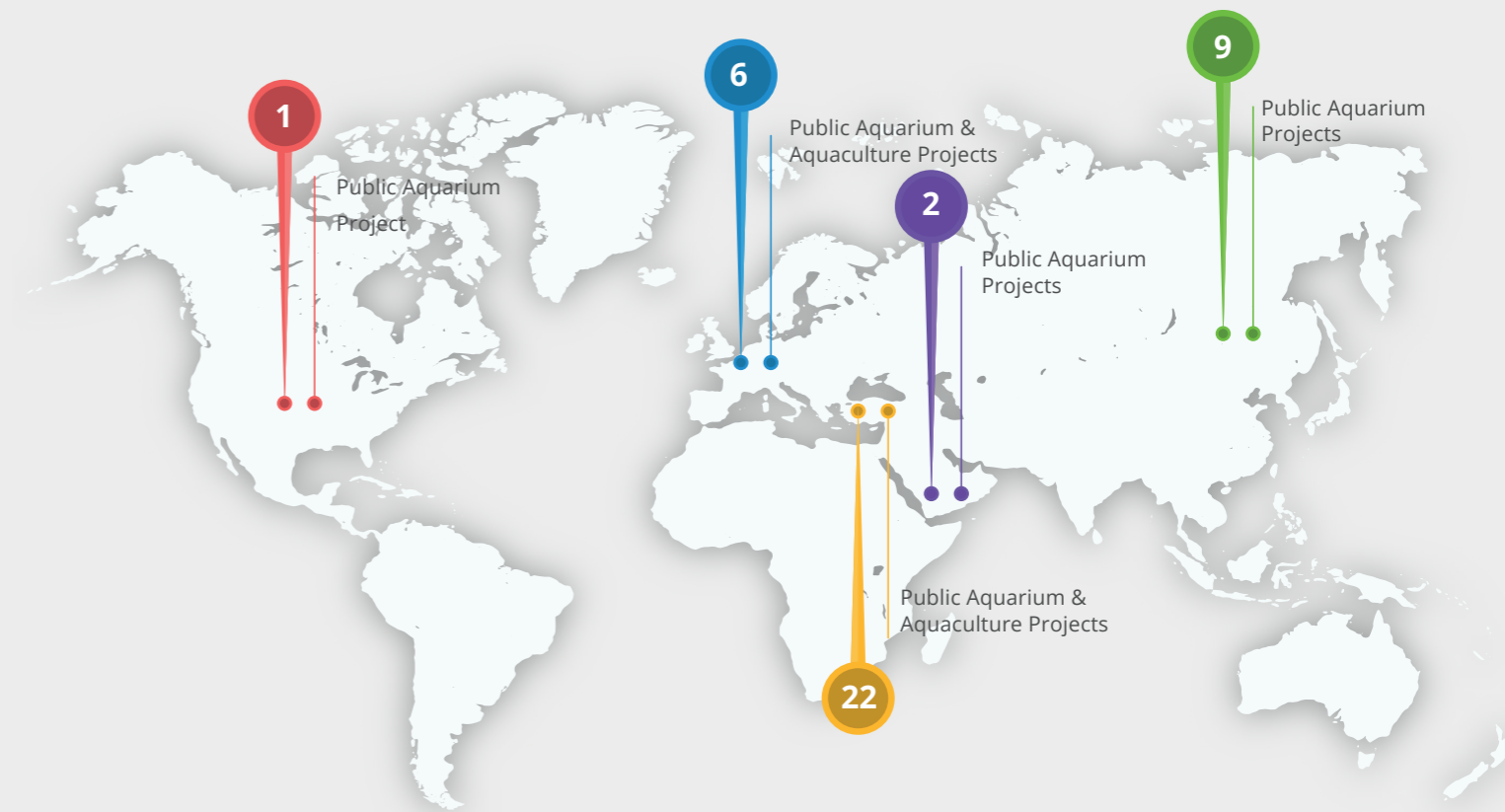

OceanTech has emerged as a **global filtration brand**, having successfully implemented over 100 completed projects around the world. Our proven expertise and passion for work ensures we guarantee excellence in the products and services we provide.

Sustainability

OCEANTECH™ prioritizes environmental sustainability by developing eco-friendly LSS products, promoting the well-being of aquatic ecosystems.



Highest Quality

OCEANTECH™ brand is dedicated to delivering products of the highest quality while meeting and exceeding industry standards to ensure exceptional performance and customer satisfaction.



Durability

OCEANTECH™ products are engineered for longevity and reliability, designed to withstand demanding conditions and heavy usage, minimizing downtime and maximizing operational efficiency.



nurturing aquatic life,
sustaining the future.



Our Solution Partners



Authorized Distributor for Ultraqua in Turkey

We are the authorized distributor of Ultraqua's UV disinfection systems in Turkey, offering advanced and reliable solutions for water treatment and microbial control. Our focus is on providing exceptional customer service and assisting clients in selecting the most suitable UV systems to ensure water safety and purity.

Exclusive Distributor of ADEC in Australia

Our trusted distributor in Australia, Into Aqua, with their reliable products and expertise in water treatment, purification, and more, we are proud to partner with Into Aqua to serve our valued customers in Australia. Together, we aim to contribute to water management and sustainability with Into Aqua's excellent distribution network.



Distributor for Dryden Aqua in Turkey and the Middle East

We are the distributor for Dryden Aqua in Turkey and the Middle East. Dryden Aqua is known for its innovative and sustainable filtration products and AFM (Activated Filter Media). Our partnership aims to provide high-performance filtration solutions to meet diverse water quality needs in aquaculture industry.



Authorized Distributor for ADEC in Belgium

Aquamatters is our distributor in Belgium, offering a comprehensive range of water solutions and services. Together, we are committed to providing high-quality products and exceptional support to customers in Belgium, focusing on water treatment, filtration, and environmental sustainability. Our partnership aims to enhance water management and address diverse water challenges in the region.



Exclusive Distributor for Abyzz in Turkey and the Middle East

We are delighted to be the exclusive distributor of Abyzz products in Turkey and the Middle East, offering their cutting-edge aquarium solutions to customers in the region. This partnership allows us to bring Abyzz's state-of-the-art pumps and controllers to aquarium enthusiasts, ensuring enhanced aquatic experiences through our dedicated distribution network.



Distributor of ADEC in Russia

Aquaterix serves as our esteemed distributor in Russia, offering a wide array of aquatic solutions. With a shared commitment to excellence, we strive to deliver top-quality products and support to our valued customers in Russia. Through this collaboration, we aim to address various water needs.



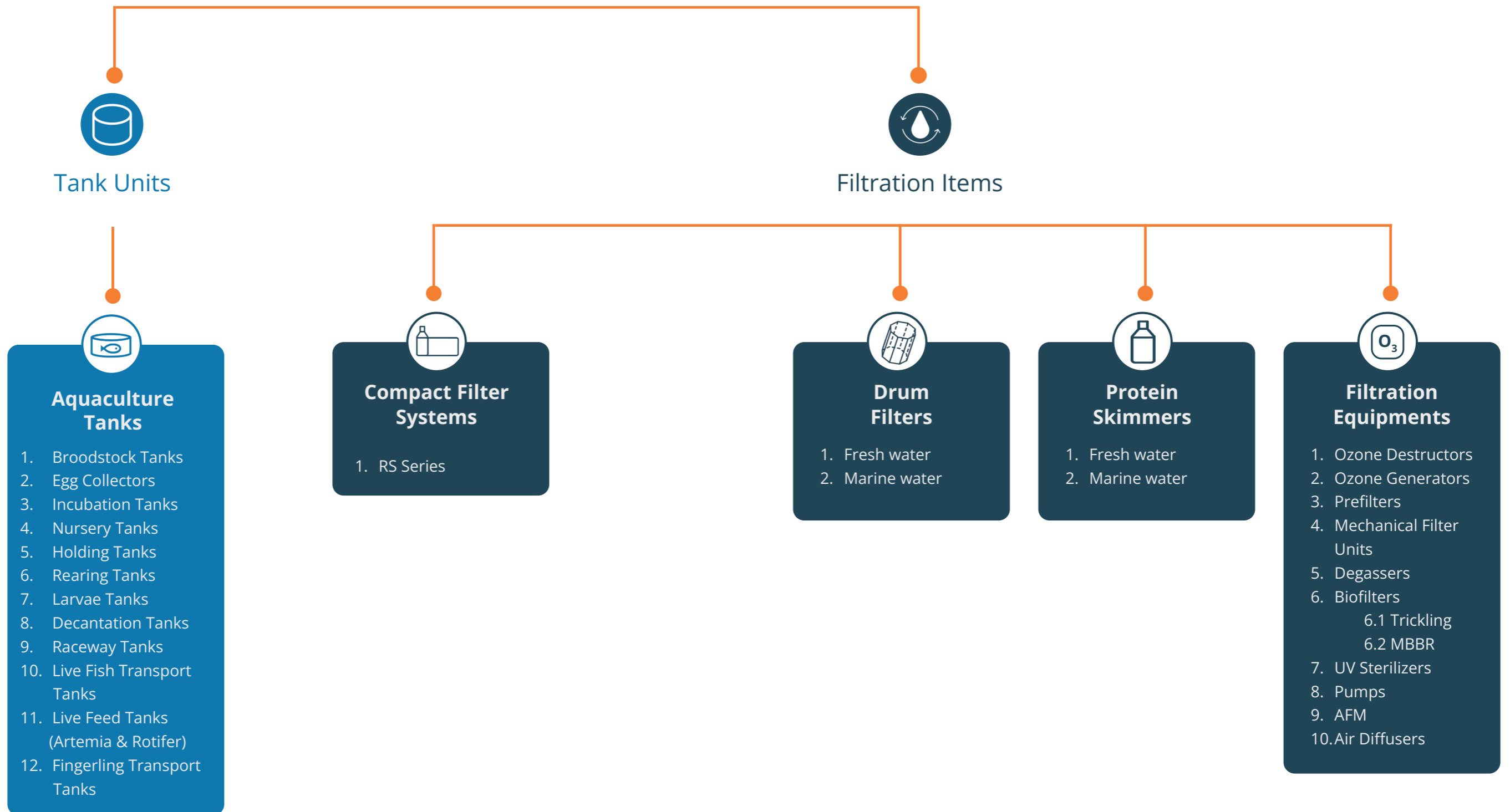

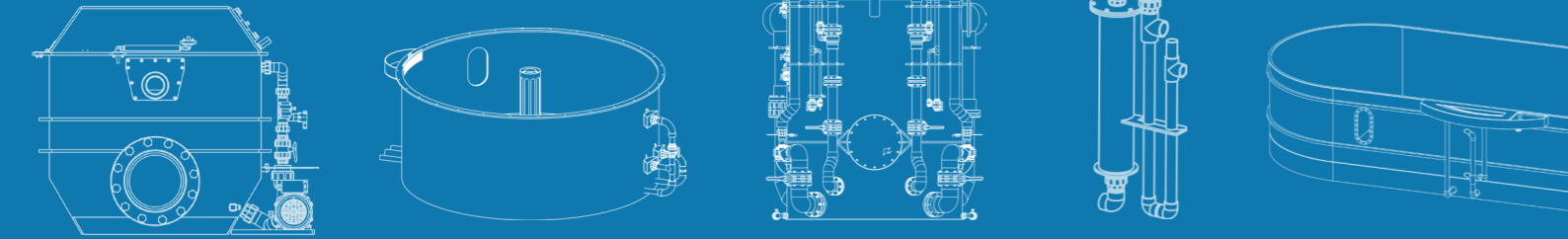

COMPACT FILTER UNITS

The OCEANTECH™ Compact Filter Units are designed by industry experts who have extensive **on-site experience** and are the **most efficient filtration** unit on the market.

They provide multiple filtration processes **in a single unit**, with **low energy consumption** and **minimal space requirements**. All units are compatible with ozone injection.

Available Compact Filter Units

- ✓ RS-10
- ✓ RS-10 PLUS



Compact Filter Units

User Benefits

- ✓ Durability, long lasting
- ✓ Minimal maintenance
- ✓ Low operating cost
- ✓ Low energy consumption
- ✓ Expandable and customizable
- ✓ Touch Screen PLC Automation
- ✓ Available with SCADA integration
- ✓ For both fresh and saltwater applications
- ✓ Compatible with ozone injection



RS Series

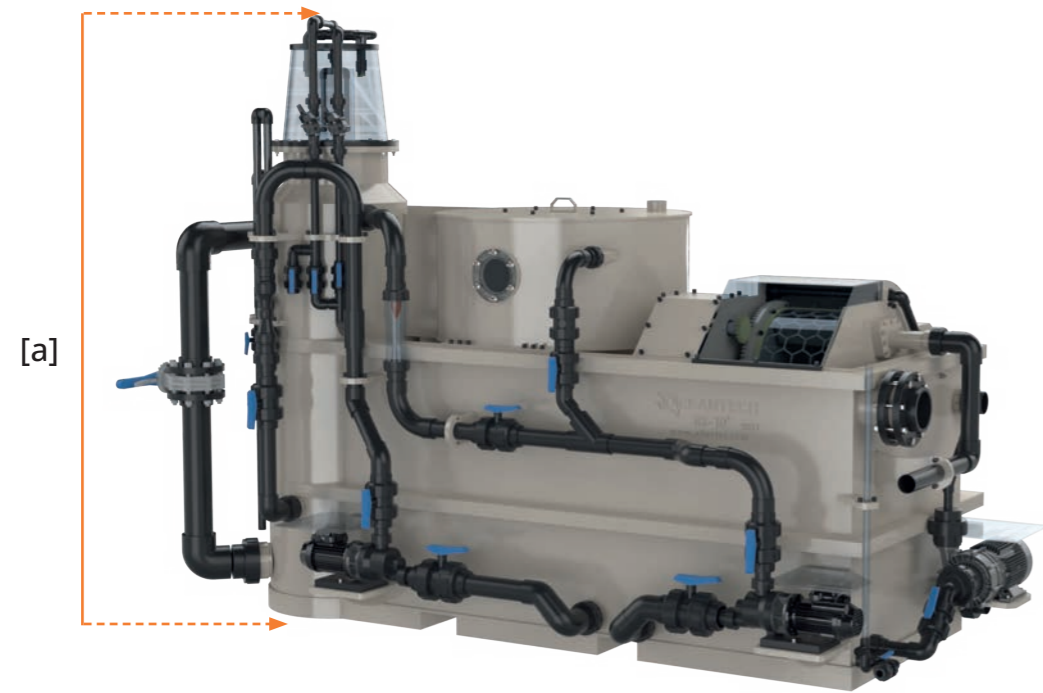

The OCEANTECH™ RS Series provides **multiple filtration** processes in a single unit, with **low energy consumption** and **minimal space requirements**. It is compatible with the patented Oceantech AF series and BF series.

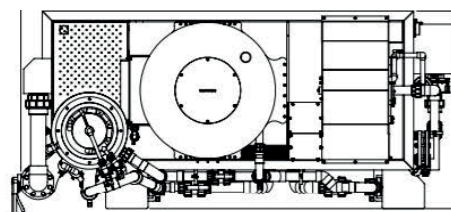

Top View

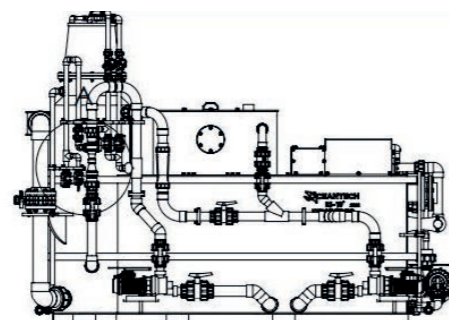

Front View

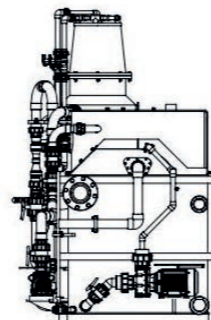

Side View

Technical Specifications

		MODEL	RS-10	RS-10 PLUS
Material Used	Body Material		PP	PP
	Pump Quantity		3 pcs	3 pcs
	Venturi Quantity		1 pcs	1 pcs
	Pump Protection		Standard	Standard
	Flow meter		Standard	Standard
	Auto Foam Rinse		Standard	Standard
	Water Level Sensor		Standard	Standard
	Water Level Pressure Sensor		Standard	Standard
	ORP Prob		Optional	Optional
	pH Prob		Optional	Optional
	PLC Control Panel		Optional	Optional
	Manual Control Panel		Optional	Optional
Performance	PS Capacity (2 RT)		10,8 m ³ /h	10,8 m ³ /h
	PS Capacity (1,5 RT)		14,4 m ³ /h	14,4 m ³ /h
	PS Capacity (1 RT)		21,6 m ³ /h	21,6 m ³ /h
	Venturi Pump Power		0,45 kW	0,45 kW (3~, 400V)
	Stand-by Nozzle Pump Power		1,6 kW	1,6 kW (3~, 400V)
	Feed Pump Power		0,25 kW	0,25 kW (3~, 400V)
	DC Motor Power		0,32 kW	0,32 kW
	Operational Power		1,28 kW	1,28 kW
	Drum Filter Capacity (36 μ Mesh) (Changeable)		33 m ³ /h	33 m ³ /h
	Drum Filter Backwash Consumption		6,5 L/min	6,5 L/min
	Trickle Volume		0,32 m ³	0,32 m ³
	MBBR Volume		-	0,32 m ³
	Compact Unit Nominal Flow		6,5-13 m ³ /h	13-21 m ³ /h
	Biological Surface Area		99,2 m ²	227 m ²
	Recommended Ozone Dosage		250 mg/h	250 mg/h
	Dry Weight		250 kg	350 kg
	Operational Weight		1030 kg	2300 kg
Operational Water Volume		0,66 m ³	1,6 m ³	
Dimensions	Footprint		1994 mm x 1398 mm	3118 mm x 1415 mm
	PS Diameter		Ø 545 mm	Ø 545 mm
	Max Height [a]		2261 mm	2272 mm
	Drum Filter Diameter		Ø 490 mm	Ø 490 mm
	Drum Filter Length		340 mm	340 mm
	Sump Max Water Level		865 mm	865 mm
	Water Inlet		Ø 125 mm	Ø 125 mm
	Water Inlet Center Height		945 mm	945 mm
	Pump Suction Connection Diameter		Ø 75 mm	Ø 90 mm
	Operational Water Level		700 mm	700 mm

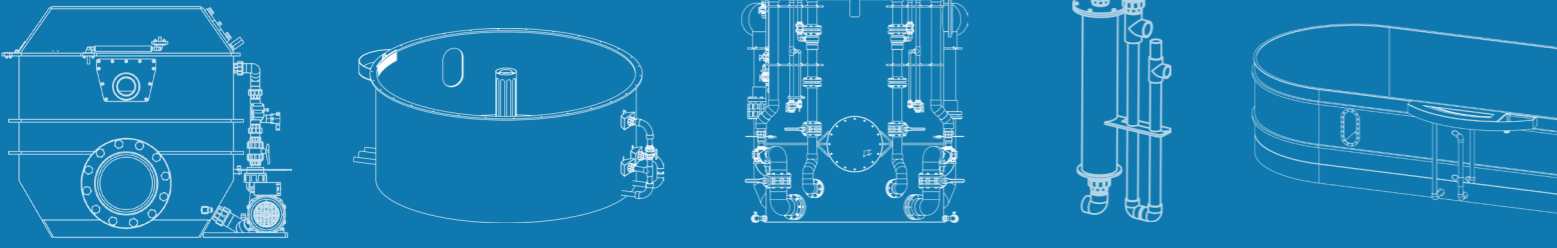

DRUM FILTERS

The OCEANTECH™ **Drum Filters** offer a range of advantages that make them the ideal choice for your filtration needs. With their **innovative design** and advanced fe-

atures, these filters provide exceptional performance and efficiency. They are compatible with the patented **Oceantech AF series** and **BF series**.

Available DRM Versions

- ✓ DRM-25
- ✓ DRM-50
- ✓ DRM-100
- ✓ DRM-150
- ✓ DRM-200
- ✓ DRM-250

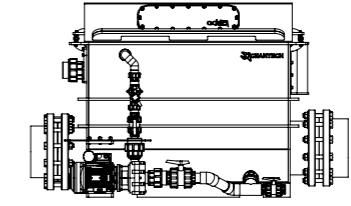

Drum Filters

User Benefits

- ✓ Durability, long lasting
- ✓ Minimal maintenance
- ✓ Minimum energy consumption
- ✓ Expandable and customizable
- ✓ Available with SCADA integration
- ✓ For both fresh and saltwater applications
- ✓ Compatible with ozone injection



DRM Series

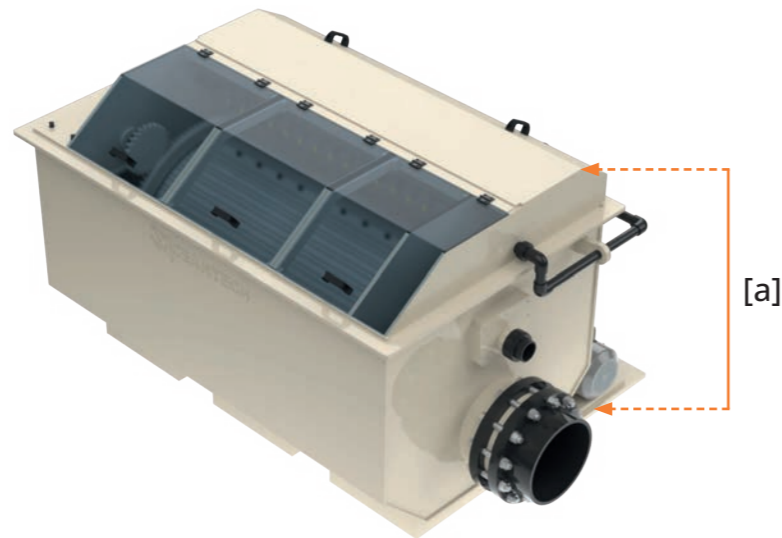

SPECK X pumps FIP SIMONA

OCEANTECH™ **Drum Filters** are the ultimate solution for your filtration requirements. They are engineered using **cutting-edge technology** and can be used as stand alone filtration units making them the perfect choice for your **aquatic systems**.

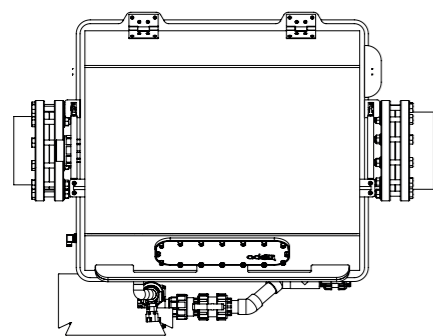

Top View

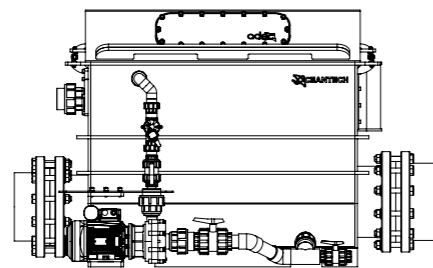

Front View

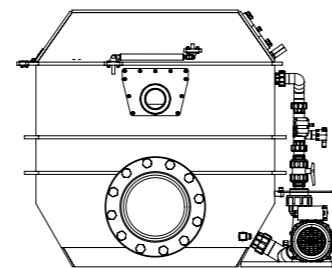

Side View

Technical Specifications							
MODEL		DRM-25	DRM-50	DRM-100	DRM-150	DRM-200	DRM-250
Material Used	Body Material	PP	PP	PP	PP	PP	PP
	Screen Material	PP	PP	PP	PP	PP	PP
	Screen Panel Quantity	1 pcs	1 pcs	1 pcs	2 pcs	2 pcs	2 pcs
	Filter Housing Material	PP	PP	PP	PP	PP	PP
	Control System	PLC	PLC	PLC	PLC	PLC	PLC
Performance	Flowrate	25 m ³ /hr	50 m ³ /hr	100 m ³ /hr	150 m ³ /hr	200 m ³ /hr	250 m ³ /hr
	Backwash Pump Voltage	220/380/400 V AC					
	Backwash Pump Power	1,6 kW	1,6 kW	1,6 kW	1,6 kW	1,6 kW	1,6 kW
	Drive Unit Voltage	220/380/400 V AC					
	Drive Unit Power	0,25 kW	0,25 kW	0,25 kW	0,25 kW	0,25 kW	0,25 kW
	Weight	55 kg	96 kg	175 kg	220 kg	245 kg	297 kg
Dimensions	Footprint	500 mm x 1200 mm	1100 mm x 1900 mm	1100 mm x 2250 mm	1345 mm x 2850 mm	1450 mm x 2850 mm	2200 mm x 3850 mm
	Drum Diameter	Ø 400 mm	Ø 450 mm	Ø 650 mm	Ø 650 mm	Ø 800 mm	Ø 960 mm
	Height [a]	750 mm	820 mm	1135 mm	1200 mm	1250 mm	1300 mm
	Mash Size	85 µ	85 µ	85 µ	85 µ	85 µ	85 µ
	Drum Length	550 mm	750 mm	1200 mm	1600 mm	1600 mm	1750 mm
	Thickness	10 mm	10 mm	10 mm	10 mm	10 mm	10 mm
	Filtration Area	0,37 m ²	0,69 m ²	1,59 m ²	2,12 m ²	2,45 m ²	3,43 m ²
	Drain Diameter	Ø 63 mm	Ø 75 mm	Ø 75 mm	Ø 75 mm	Ø 90 mm	Ø 110 mm
	Inlet Diameter	Ø 140 mm	Ø 200 mm	Ø 280 mm	Ø 315 mm	Ø 355 mm	Ø 400 mm
	Outlet Diameter	Ø 140 mm	Ø 200 mm	Ø 280 mm	Ø 315 mm	Ø 355 mm	Ø 400 mm

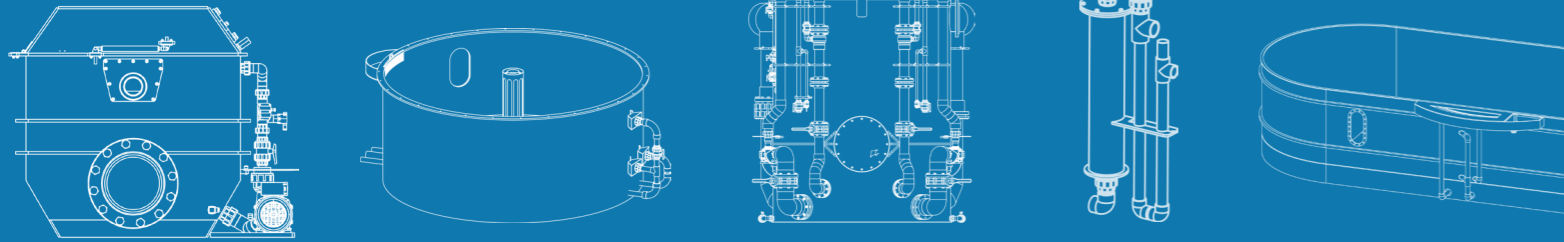

PROTEIN SKIMMERS

The OCEANTECH™ **Protein Skimmers** are an **effective** and **reliable** item of equipment that significantly enhances the **water quality in your aquatic systems**. They

can efficiently remove harmful organic proteins and waste from both the surface and lower layers of the water to ensure **water clarity** and **cleanliness**.

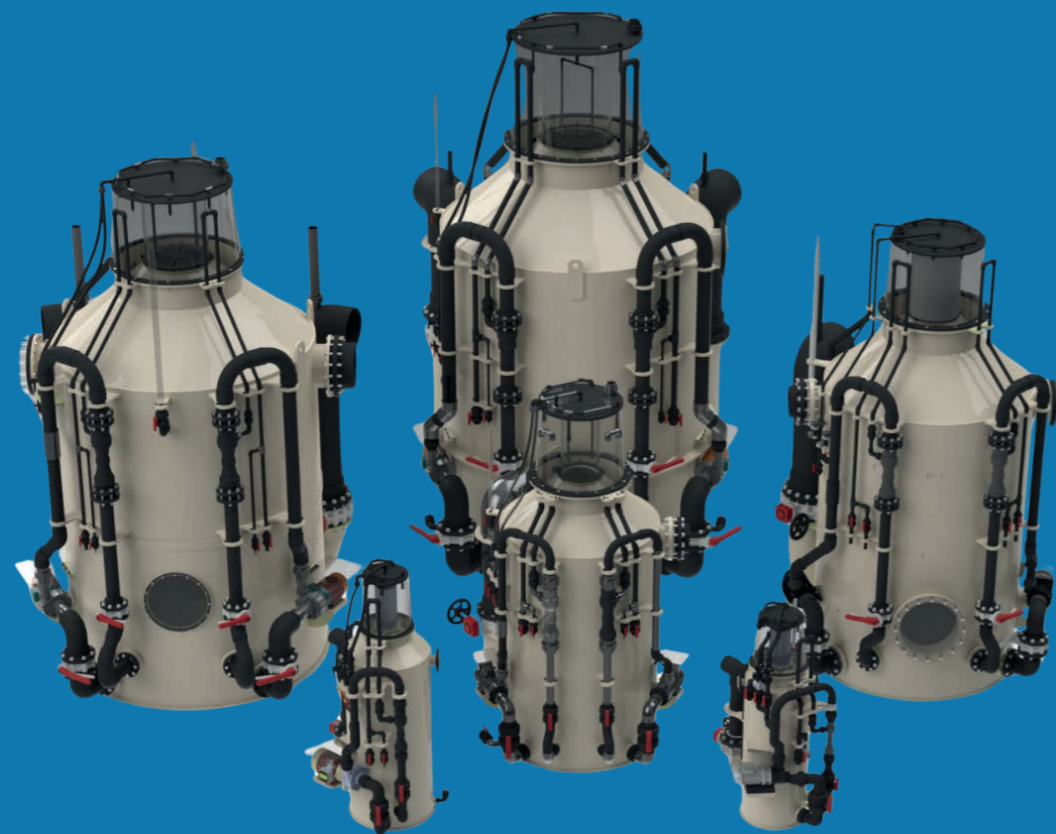

Protein Skimmers

User Benefits

- ✓ Durability, long lasting
- ✓ Minimal maintenance
- ✓ Minimum energy consumption
- ✓ Expandable and customizable
- ✓ Available with SCADA integration
- ✓ For saltwater applications



MS-05 ↔ MS-40

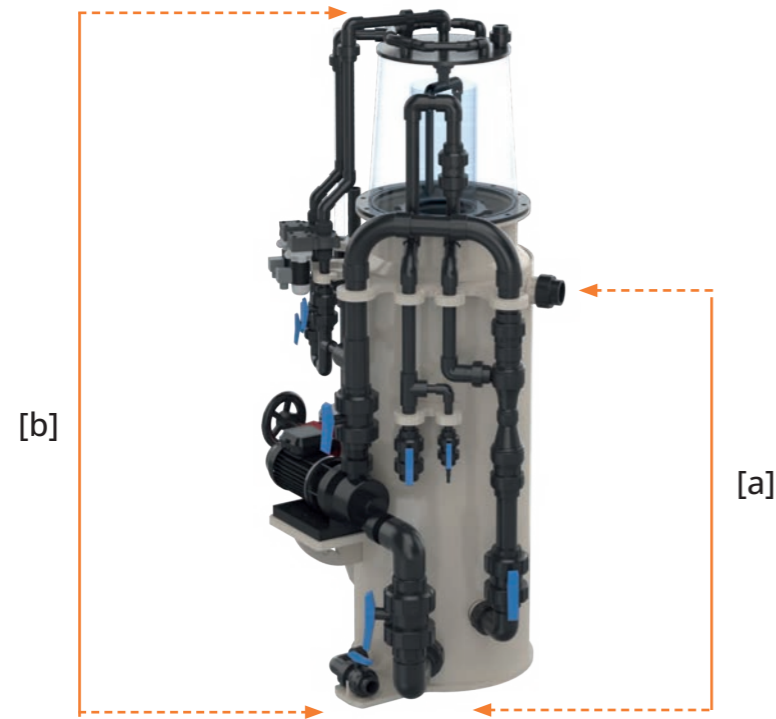

SPECK X pumps SIMONA FIP

The OCEANTECH™ **Protein Skimmers** are used to separate microscopic organic compounds, protein particulate, amino acids, harmful bacteria and other detritus from **saltwater systems**. We provide **customisable options** to suit various requirements and needs. With our advanced technology it ensures energy efficiency and delivers **long-lasting performance** with **low operating costs**.

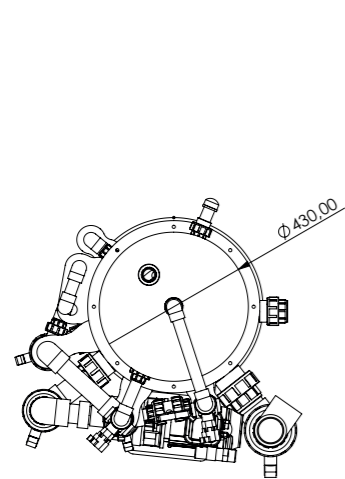

Top View

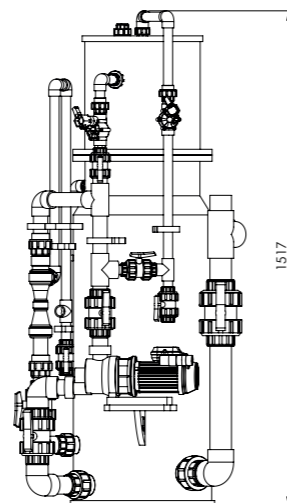

Side View

Technical Specifications

MODEL		MS-05	MS-10	MS-20	MS-30	MS-40
Material Used	Body Material	PP	PP	PP	PP	PP
	Venturi Quantity	1	1	1	1	1
	Pump Protection	Standard	Standard	Standard	Standard	Standard
	Auto Foam Rinse	Standard	Standard	Standard	Standard	Standard
	Manual Control Panel	Optional	Optional	Optional	Optional	Optional
	PLC Control Panel	Optional	Optional	Optional	Optional	Optional
Performance	Manhole	-	-	-	-	-
	Glazed View	-	-	-	-	-
	Capacity (1 RT)	8,2 m ³ /h	15,2 m ³ /h	29,5 m ³ /h	45,8 m ³ /h	61,9 m ³ /h
	Capacity (1,5 RT)	5,5 m ³ /h	10 m ³ /h	20 m ³ /h	30 m ³ /h	40 m ³ /h
	Capacity (2 RT)	4,1 m ³ /h	7,6 m ³ /h	14,7 m ³ /h	22,9 m ³ /h	30,9 m ³ /h
	Power Consumption	0,42 kW	0,69 kW	0,71 kW	0,71 kW	0,97 kW
	Dry Weight	45 kg	60 kg	90 kg	115 kg	150 kg
	Operational Weight	198 kg	315 kg	620 kg	880 kg	1201 kg
Dimensions	Footprint	809 mm x 629 mm	895 mm x 708 mm	1080 mm x 870 mm	1215 mm x 980 mm	1347 mm x 1096 mm
	Diameter	Ø 430 mm	Ø 520 mm	Ø 720 mm	Ø 800 mm	Ø 800 mm
	Inlet Height [a]	947 mm	1195 mm	1208 mm	1518 mm	2053 mm
	Outlet Height	910 mm	1100 mm	1300 mm	1450 mm	1650 mm
	Total Height [b]	1517 mm	1996 mm	2117 mm	2369 mm	2859 mm
	Inlet Pipe Diameter	Ø 50 mm	Ø 63 mm	Ø 90 mm	Ø 110 mm	Ø 125 mm
	Outlet Pipe Diameter	Ø 75 mm	Ø 90 mm	Ø 140 mm	Ø 160 mm	Ø 200 mm

PROTEIN SKIMMERS

PROTEIN SKIMMERS

MS-80 ↔ MS-200

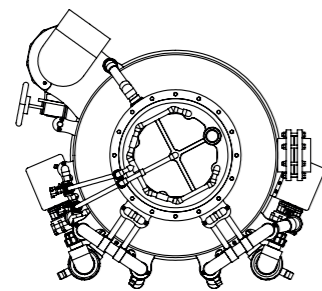
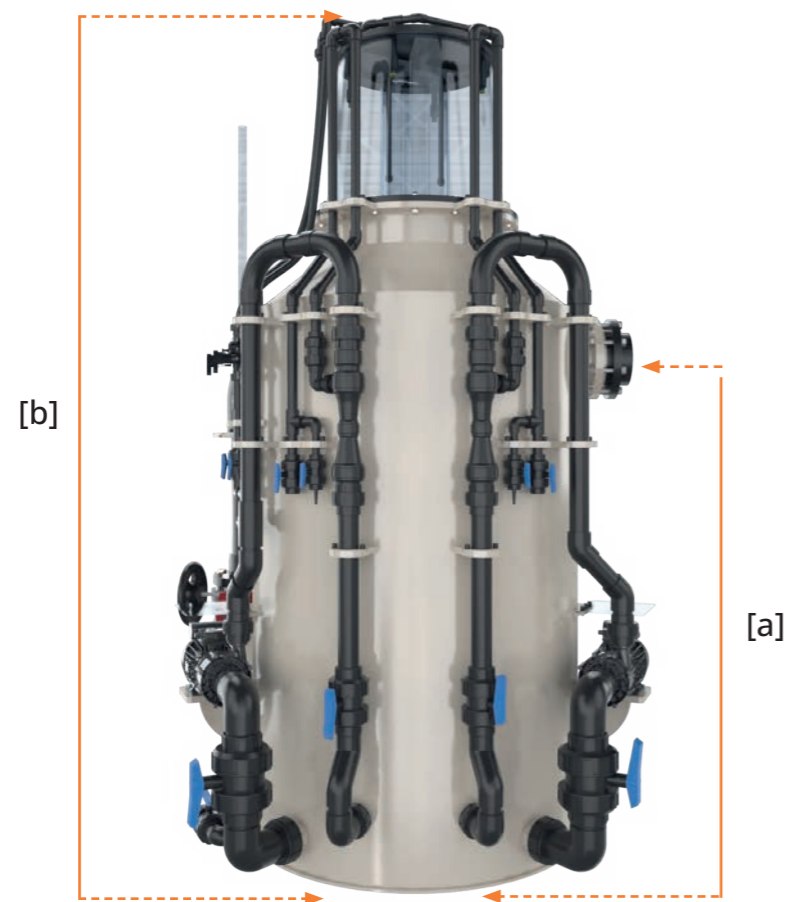

Top View

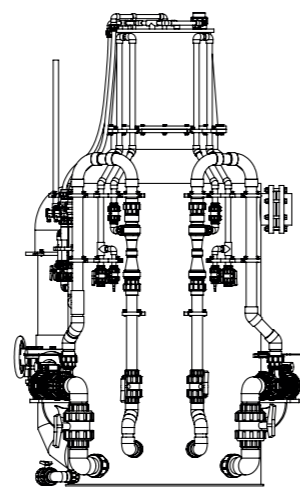

Side View

Technical Specifications

MODEL		MS-80	MS-100	MS-120	MS-160	MS-200
Material Used	Body Material	PP	PP	PP	PP	PP
	Venturi Quantity	2	2	2	2	2
	Pump Protection	Standard	Standard	Standard	Standard	Standard
	Auto Foam Rinse	Standard	Standard	Standard	Standard	Standard
	Manual Control Panel	Optional	Optional	Optional	Optional	Optional
	PLC Control Panel	Optional	Optional	Optional	Optional	Optional
Performance	Manhole	-	-	Optional	Optional	Optional
	Glazed View	Optional	Optional	Optional	Optional	Optional
	Capacity (1 RT)	118,8 m ³ /h	150,6 m ³ /h	180,1 m ³ /h	240 m ³ /h	300 m ³ /h
	Capacity (1,5 RT)	80 m ³ /h	100 m ³ /h	120 m ³ /h	160 m ³ /h	200 m ³ /h
	Capacity (2 RT)	59,4 m ³ /h	75,3 m ³ /h	90 m ³ /h	120 m ³ /h	150 m ³ /h
	Power Consumption	1,42 kW	1,94 kW	3,8 kW	3,8 kW	3,8 kW
	Dry Weight	220 kg	265 kg	315 kg	350 kg	510 kg
	Operational Weight	2301 kg	2856 kg	3406 kg	4563 kg	5732 kg
Dimensions	Footprint	1663 mm x 1475 mm	1677 mm x 1753 mm	1908 mm x 1712 mm	2136 mm x 1926 mm	2230 mm x 2010 mm
	Diameter	Ø 1130 mm	Ø 1270 mm	Ø 1300 mm	Ø 1450 mm	Ø 1600 mm
	Inlet Height [a]	1975 mm	1983 mm	2262 mm	2424 mm	2488 mm
	Outlet Height	1650 mm	1750 mm	1850 mm	2100 mm	2250 mm
	Total Height [b]	2864 mm	2914 mm	3173 mm	3368 mm	3492 mm
	Inlet Pipe Diameter	Ø 160 mm	Ø 200 mm	Ø 200 mm	Ø 225 mm	Ø 200 mm
	Outlet Pipe Diameter	Ø 250 mm	Ø 280 mm	Ø 280 mm	Ø 315 mm	Ø 355 mm

MS-250 ↔ MS-1000

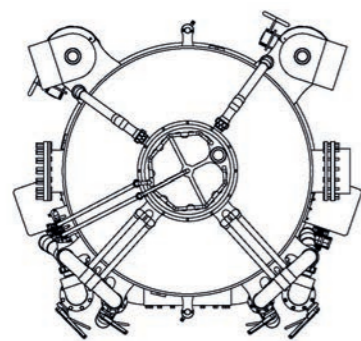
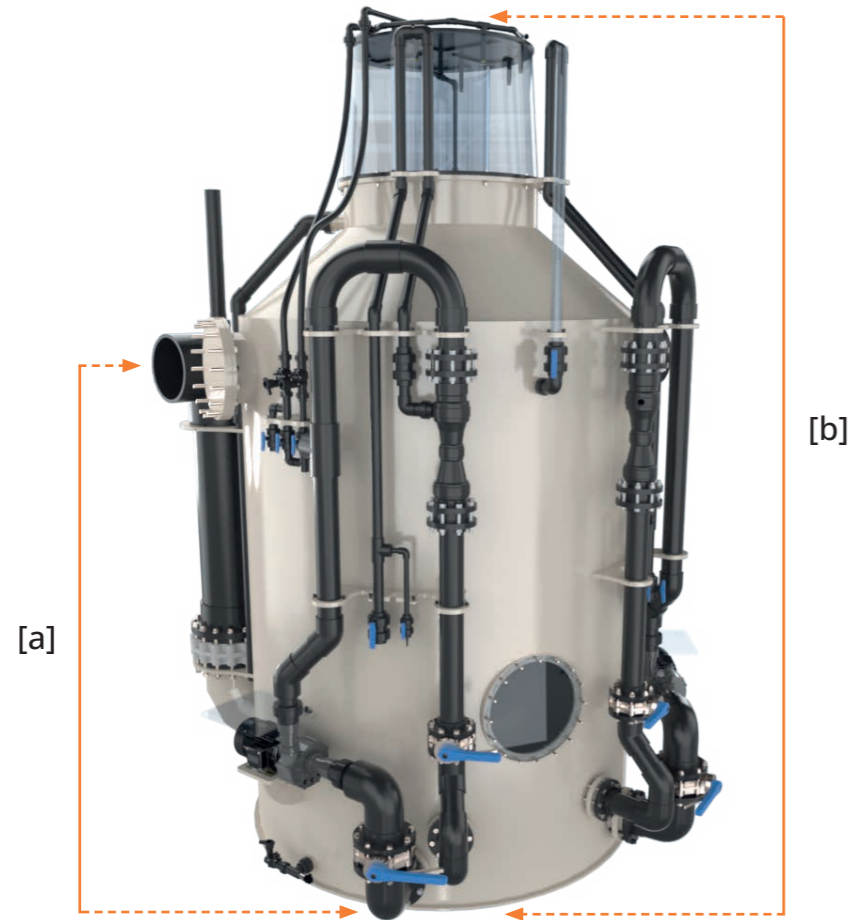

Top View

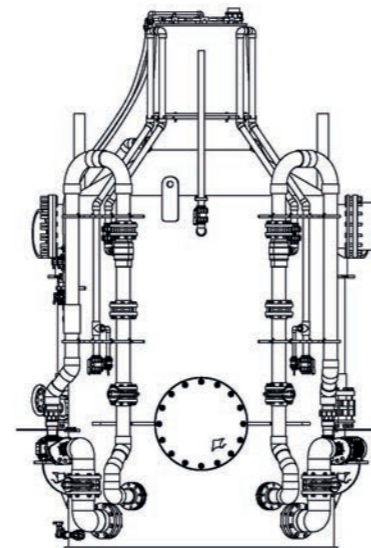

Side View

Technical Specifications

MODEL		MS-250	MS-350	MS-450	MS-600	MS-750	MS-1000
Material Used	Body Material	PP	PP	PP	PP	PP	PP
	Venturi Quantity	2	2	2	2	3	3
	Pump Protection	Standard	Standard	Standard	Standard	Standard	Standard
	Auto Foam Rinse	Standard	Standard	Standard	Standard	Standard	Standard
	Manual Control Panel	Optional	Optional	Optional	Optional	Optional	Optional
	PLC Control Panel	Optional	Optional	Optional	Optional	Optional	Optional
Performance	Manhole	Optional	Optional	Optional	Optional	Optional	Optional
	Glazed View	Optional	Optional	Optional	Optional	Optional	Optional
	Capacity (1 RT)	375,4 m ³ /h	524,5 m ³ /h	672,5 m ³ /h	900,7 m ³ /h	1125,1 m ³ /h	1495,9 m ³ /h
	Capacity (1,5 RT)	250 m ³ /h	350 m ³ /h	450 m ³ /h	600 m ³ /h	750 m ³ /h	1000 m ³ /h
	Capacity (2 RT)	187,7 m ³ /h	262,3 m ³ /h	336,2 m ³ /h	450,4 m ³ /h	562,5 m ³ /h	748 m ³ /h
	Pump Power	5,1 kW	6,9 kW	6,9 kW	9,1 kW	13,65 kW	13,65 kW
	Dry Weight	620 kg	790 kg	905 kg	1400 kg	1600 kg	1750 kg
	Operational Weight	7179 kg	9817 kg	12492 kg	16771 kg	20868 kg	27587 kg
Dimensions	Footprint	2467 mm x 2207 mm	2605 mm x 2410 mm	2911 mm x 2661 mm	3275 mm x 2975 mm	3655 mm x 3305 mm	4015 mm x 3700 mm
	Diameter	Ø 1800 mm	Ø 2050 mm	Ø 2200 mm	Ø 2450 mm	Ø 2730 mm	Ø 2960 mm
	Inlet Height	2460 mm	2650 mm	2950 mm	3186 mm	3205 mm	3625 mm
	Outlet Height [a]	2350 mm	2350 mm	2550 mm	2750 mm	2750 mm	3150 mm
	Total Height [b]	3854 mm	4160 mm	4371 mm	4756 mm	4720 mm	5230 mm
	Inlet Pipe Diameter	Ø 280 mm	Ø 315 mm	Ø 355 mm	Ø 355 mm	Ø 400 mm	Ø 400 mm
	Outlet Pipe Diameter	Ø 400 mm	Ø 400 mm	Ø 400 mm	Ø 400 mm	Ø 400 mm	Ø 400 mm

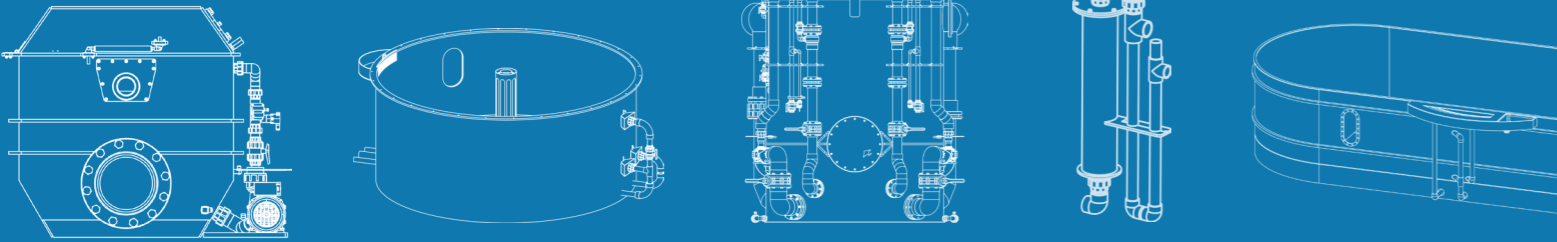

FILTRATION EQUIPMENTS

MECHANICAL FILTER UNITS

The OCEANTECH™ Mechanical Filtration Units are specifically designed to work in **conjunction with AFM** (Activated Filter Media) filtration media, to provide the most effective mechanical filtration. The **Solid HDPE**

(High-Density Polyethylene) filter housing is the first and only application in the aquatic industry, providing durability and a long life cycle-thereby **reducing your ROI**.

Available Mechanical Filter Units

- ✓ AF - 450 U
- ✓ AF - 630 U
- ✓ AF - 800 U
- ✓ AF - 1000 U



Mechanical Filter Units

User Benefits

- ✓ Durability, long lasting
- ✓ Minimal maintenance
- ✓ Minimum energy consumption
- ✓ Expandable and customizable
- ✓ Available with SCADA integration
- ✓ Best filter media (AFM)
- ✓ For both fresh and saltwater applications



AFU Series



Materials Used	
Pressure Sensor	Standard
Temperature Sensor	Standard
Flow Switch	Standard
Prefilter Pump	Optional
Flow meter	Optional
Automatic Back Wash	Optional
Besgo Valve	Optional
Acrylic Lid	Optional



The OCEANTECH™ **AFU series** hydraulically engineered for **optimal filtration velocity** both in filtration and backwash phases to **ensure enough space** for bed expansion. This results in **efficient** and **effective backwashing** of the filter. The standardised nozzle plate distribution and uniform cylindrical body enables the **complete utilisation** of the filter bed.

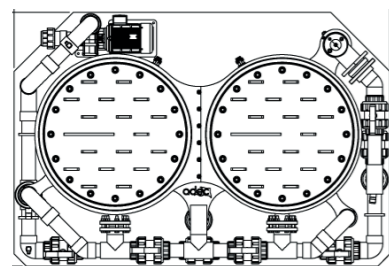

Top View

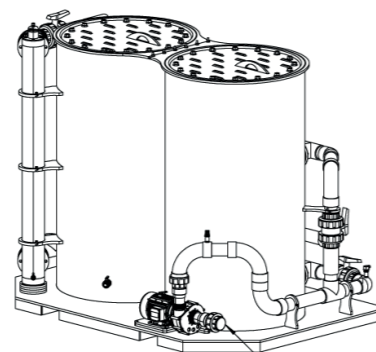

Front View

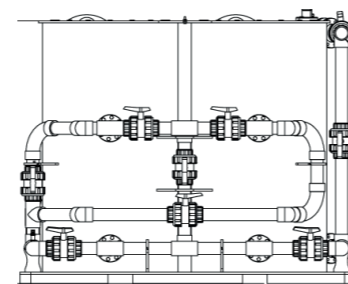

Side View

Technical Specifications					
MODEL		AF-450U	AF-630U	AF-800U	AF-1000U
Material Used	Body Material	PE	PE	PE	PE
	Mechanical Cylinder Quantity	2 pcs	2 pcs	2 pcs	2 pcs
	Pump Quantity	1 pcs	1 pcs	1 pcs	1 pcs
	UV Quantity	1 pcs	1 pcs	1 pcs	1 pcs
	Nozzle Quantity	26 pcs	42 pcs	62 pcs	102 pcs
	Performance	Mechanical Unit Capacity (23 m/h)	6,7 m³/h	13 m³/h	20,9 m³/h
Mechanical Unit Pump Power		0,66 kW	0,71 kW	0,97 kW	1,9 kW
UV Capacity (400 J/m²)		9 m³/h	19,5 m³/h	23 m³/h	36 m³/h
UVT		85%	85%	90%	90%
UV Power		0,2 kW	0,2 kW	0,2 kW	0,4 kW
Total Power		0,86 kW	0,91 kW	1,17 kW	2,3 kW
Water Inlet Pipe Section Velocity		0,73 m/sec	0,9 m/sec	1,08 m/sec	0,82 m/sec
Water Outlet Pipe Section Velocity		1,16 m/sec	1,30 m/sec	1,4 m/sec	1,57 m/sec
Mechanical Unit Backwash Flow		6,7 m³/h	13 m³/h	41,8 m³/h	36 m³/h
AFM Grade 2		4 Bag (25 kg/bag)	7 Bag (25 kg/bag)	10 Bag (25 kg/bag)	14 Bag (25 kg/bag)
AFM Grade 1		9 Bag (25 kg/bag)	17 Bag (25 kg/bag)	27 Bag (25 kg/bag)	44 Bag (25 kg/bag)
Dry Weight		152 kg	250 kg	375 kg	634 kg
Operational Weight		565 kg	1070 kg	2520 kg	3220 kg
Dimensions		Footprint	1165 mm x 883 mm	1578 mm x 1113 mm	1941 mm x 1303 mm
	Mechanical Diameter	Ø 450 mm	Ø 630 mm	Ø 800 mm	Ø 1000 mm
	Mechanical Filter Section Area	0,28 m²	0,56 m²	0,9 m²	1,42 m²
	Max Height	1878 mm	1878 mm	1878 mm	2067,5 mm
	Water Inlet	Ø 63 mm	Ø 75 mm	Ø 110 mm	Ø 125 mm
	Water Outlet	Ø 63 mm	Ø 63 mm	Ø 75 mm	Ø 90 mm

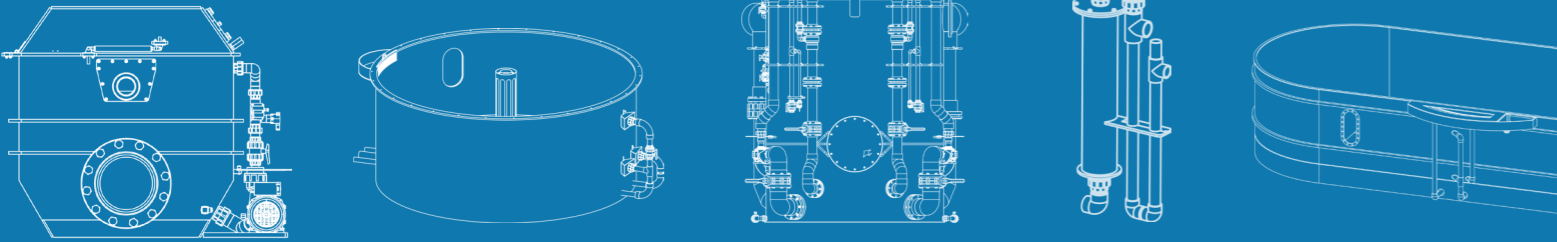

FILTRATION EQUIPMENTS

OZONE DESTRUCTORS

The OCEANTECH **Ozone destructors** quickly **convert the ozone gas** in the system **into oxygen** by removing toxic gases such as carbon monoxide and carbon dioxide. This

ensure to help **produce a safe and efficient operation** for **your staff** and **aquatic species**. They are compatible with the patented Oceantech CS & RS series.

Available Ozone Destructors

- ✓ ESM Series
- ✓ SLN Series



Ozone Destructors

User Benefits

- ✓ Durability, long lasting
- ✓ Minimal maintenance
- ✓ Minimum energy consumption
- ✓ Expandable and customizable
- ✓ Available with SCADA integration
- ✓ For both fresh and saltwater applications



ESM Series



SIMONA 

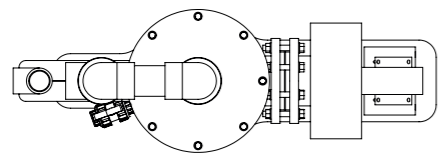

Top View

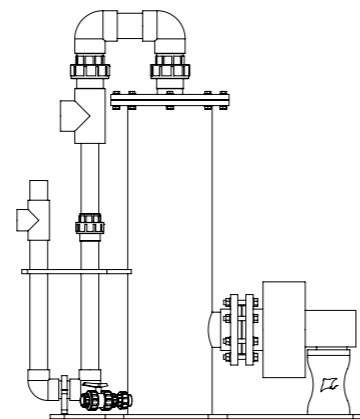

Side View

Technical Specifications

Model	ESM-300	ESM-400	ESM-620
Body Material	PP	PP	PP
Pipe Material	UPVC	UPVC	UPVC
Radial Blower	Standard	Standard	Standard
Footprint	1450 mm x 1250 mm x 420 mm	1500 mm x 1350 mm x 520 mm	1540 mm x 1800 mm x 740 mm
Ozone Elimination	5 gr/L	5 gr/L	5 gr/L
Air Flow	42 m ³ /hr	75 m ³ /hr	180 m ³ /hr
Carbon	28,3 lt	50 lt	120 lt
Diameter	300 mm	400 mm	620 mm
Dry Load	50 kg	60 kg	80 kg
Nominal Voltage	380 V / 50 Hz	380 V / 50 Hz	380 V / 50 Hz
Nominal Current	0,85 A	0,85 A	1 A
Engine Output Power	250 W	250 W	370 W
Noise Level	49	49	63

SLN Series



SIMONA 

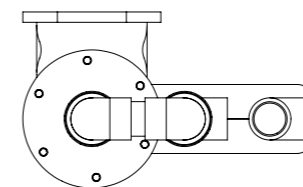

Top View

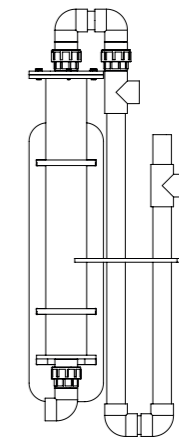

Side View

Technical Specifications

Model	SLN-110	SLN-160	SLN-200
Body Material	PP	PP	PP
Pipe Material	UPVC	UPVC	UPVC
Footprint	1150 mm x 200 mm x 450 mm	1250 mm x 250 mm x 450 mm	1350 mm x 290 mm x 580 mm
Ozone Elimination	5 gr/L	5 gr/L	5 gr/L
Air Flow	5 m ³ /hr	10 m ³ /hr	16 m ³ /hr
Carbon	5 lt	10 lt	16 lt
Diameter	110 mm	160 mm	200 mm
Dry Load	5 kg	8 kg	15 kg
Nominal Voltage	-	-	-
Nominal Current	-	-	-
Engine Output Power	-	-	-
Noise Level	-	-	-

* This series does not contain any electronic equipment.

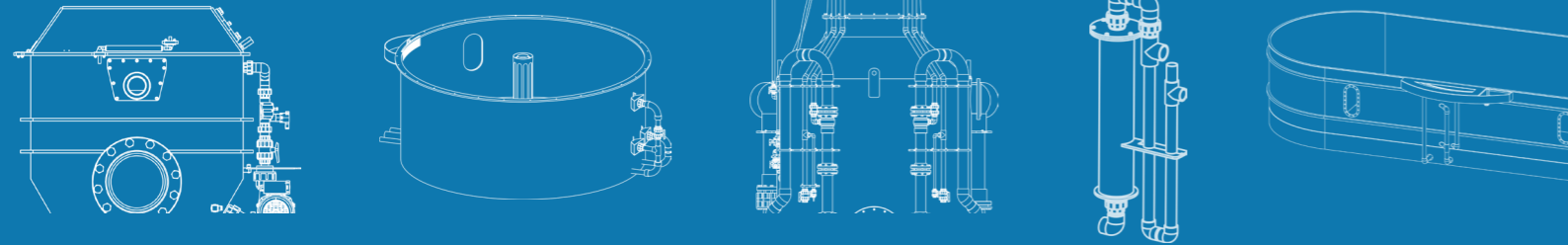

FILTRATION EQUIPMENTS

OZONE GENERATORS

Ozone gas effectively purifies and disinfects water from organic pollutants. OCEANTECH™ **Ozone Generators**, designed by

industry experts, are ideal for aquaculture facilities, ensuring pristine water quality and promoting sustainable practices.

Available Ozone Generators

- ✓ SE-15 P
- ✓ SE-10
- ✓ SE-15
- ✓ SE-25
- ✓ SE-50
- ✓ SE-100
- ✓ SE-150
- ✓ SE-200



Ozone Generators

User Benefits

- ✓ Durability, long lasting
- ✓ Minimal maintenance
- ✓ Minimum energy consumption
- ✓ Expandable and customizable
- ✓ Available with SCADA integration
- ✓ For both fresh and saltwater applications



SE Series



The OCEANTECH™ Ozone Generators provide **highly efficient results** by supplying **stable** and **safe ozone** to aquatic systems. They contain air dryers which increase the quality of the ozone gas entering the system by **removing any moisture** in the gas flow. The SE Series are compatible with the patented Oceantech CS & RS series.

Technical Specifications

Model	SE-15 P	SE-10	SE-15	SE-25	SE-50	SE-100	SE-150	SE-200
Body Material	PP	PP	PP	PP	PP	PP	PP	PP
Pipe Material	UPVC	UPVC	UPVC	UPVC	UPVC	UPVC	UPVC	UPVC
Total Power	0,11 kW	0,7 kW	0,15 kW	1,22 kW	1,8 kW	2,5 kW	5 kW	9 kW
Ozone Output	2-5 g/h	10 g/h	5-15 g/h	25 g/h	50 g/h	100 g/h	150 g/h	250 g/h
Ozone Concentration	2-5 g/m ³	5-85 g/m ³	5-53 g/m ³	5-85 g/m ³	5-83 g/m ³	5-120 g/m ³	20-105 g/m ³	20-115 g/m ³
Footprint	290 mm x 270 mm	600 mm x 500 mm	600 mm x 500 mm	600 mm x 500 mm	650 mm x 580 mm	850 mm x 500 mm	850 mm x 500 mm	1300 mm x 600 mm
Max Height	160 mm	1100 mm	165 mm	1100 mm	1350 mm	1520 mm	1520 mm	1520 mm
Power Consumption	110 W	700 W	950 W	1220 W	1800 W	2500 W	5000 W	Project Specific
Current	0,5 A	5,45 A	0,7 A	5,5 A	8,2 A	12 A	7,5 for Single Phase	Project Specific
Supply Voltage 50 Hz	220 V	220 V	220 V	220 V	220 V	220 V	380 V	380 V
Ozone Outlet Size	Grid	8mm 316CrNi						
Compressor Output of Oxygen Concentrator	-	110Lpm-6,5bar	110Lpm-6,5bar	110Lpm-6,5bar	130Lpm-6,5bar	200Lpm-6,5bar	2*200Lpm-6,5bar	2*200Lpm-6,5bar
Filtration	-	Include Oxygen Concentration - Air Filter (Active Carbon) Air Dryer (Optional)						
Device Weight	4 kg	97 kg	7,5 kg	97 kg	185 kg	195 kg	230 kg	350 kg
Electricity Connection	Monophase	Monophase	Monophase	Triphase	Triphase	Triphase	Triphase	Triphase
Ozone Generation Method	Corona Discharge							

FILTRATION EQUIPMENTS

PUMPS

SPECK X
pumps

We offer **comprehensive solutions** for aquaculture facilities and projects with the high-performance models of **Speck pumps**. Speck pumps hold a leading position in the industry, known for their **reliability** and **durability**.

From these specialized pump models operating within **specific flow ranges**, we make meticulous selections **tailored to the unique needs** of your project to ensure an efficient and effective system.



Badu Resort-AK

Flow Rate (Q) | 30-105 m³/h
Total Head (H) | 10 m



Vertical Centrifugal Series

Flow Rate (Q) | 3,5-35 m³/h
Total Head (H) | 14-225 m



BADU Block Multi Mar

Flow Rate (Q) | 105-250 m³/h
Total Head (H) | 20-25 m



BADU Powerstar

Flow Rate (Q) | 250 m³/h
Total Head (H) | 5 m



Normblock Multi Series

Flow Rate (Q) | 250-105 m³/h
Total Head (H) | 20-25 m



BADU Delta-MK

Flow Rate (Q) | 9-27 m³/h
Total Head (H) | 8 m



BADU® Novastar

Flow Rate (Q) | 100 m³/h
Total Head (H) | 5 m



BADU® Variostar

Flow Rate (Q) | 90 m³/h



BADU 21

Flow Rate (Q) | 10-103 m³/h
Total Head (H) | 8-21 m

FILTRATION EQUIPMENTS

AIR DIFFUSERS



The **Dryden Aqua Air Diffuser** is a **semi-flexible, high-efficiency** fine bubble air diffuser available in 9 different lengths, depending on the air, oxygen or carbon dioxide through-put required. It provides oxygen transfer rates of up to 5kg/kw, 10m³/h of air and 1 kg of O₂/h.

Its semi-flexible construction with its own **internal ballast** will stay on the bottom of the lagoon or pit without the need to be anchored to the floor. The Dryden Aqua Air Diffuser is **quick and easy to install** and can be maintained while air blowers are operating and water reservoir is full.

ADEC is the authorized distributor of Dryden Aqua in Turkey and the Middle East.



Technical Specifications						
Product Code	Length of diffusers	Diffuser weight	Air Flow m ³ /hr (+/-20%)	Oxygen Transfer kg of O ₂ /day per diffuser at different depths at 20°C and 50% O ₂ saturation		
				2 m depth	3 m depth	4 m depth
70000	0.33 m	0.5 kg	1	2 kg O ₂	2.5 kg O ₂	3 kg O ₂
70001	0.66 m	1.0 kg	2	4 kg O ₂	5 kg O ₂	6 kg O ₂
70002	1.00 m	1.5 kg	3	6 kg O ₂	7.5 kg O ₂	9 kg O ₂
70003	1.33 m	2.0 kg	4	8 kg O ₂	10 kg O ₂	12 kg O ₂
70004	1.66 m	2.5 kg	5	12 kg O ₂	12 kg O ₂	15 kg O ₂
70005	2.0 m	3.0 kg	6	14 kg O ₂	15 kg O ₂	18 kg O ₂
70006	2.33 m	3.5 kg	7	16 kg O ₂	17 kg O ₂	21 kg O ₂
70007	2.66 m	4.0 kg	8	18 kg O ₂	20 kg O ₂	24 kg O ₂
70008	3.0 m	4.5 kg	9	20 kg O ₂	22 kg O ₂	27 kg O ₂

AFM



AFM® **Activated Filter Media** is a direct replacement for sand, doubling the performance of sand filters without the need of additional investments in infrastructure. AFM® resists biofouling, biocoagulation and transient wormhole channeling of unfiltered water and outlasts all other filter media.

ADEC is the authorized distributor of Dryden Aqua in Turkey and the Middle East.



✓ AFM® is a highly engineered product manufactured from a specific glass type, processed to obtain the optimum particle size and shape. It is then exposed to a 3-step activation process to become self-sterilising and to acquire superior adsorption properties. During activation, the structure and the chemistry of the glass are modified.

MBBR

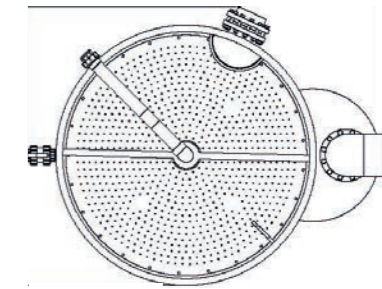

Top View

SIMONA MUTAG

OCEANTECH™ MBBRs, featuring a **conical bottom** design for structural **durability**, not only ensure **ease of maintenance and cleaning** but also come **ready for air line connection**. Ideal for aquaculture facilities, these tanks offer enduring construction for reliable performance.

Technical Specifications					
MODEL	Ø 960h1,5	Ø 1200h2	Ø 1900h1,5	Ø 1900h2	Ø 2400h1,5
Body Material	PP	PP	PP		PP
Diameter of Filter	0,96 m	1,2 m	1,9 m	1,9 m	2,4 m
Height	1500 mm	2000 mm	1500 mm	2000 mm	2400 mm
Height of Water	1350 mm	1750 mm	1250 mm	1750 mm	1250 mm
Volume of Water	0,98 m3	1,98	3,54	4,96	5,65
Fill Rate of Tank	30%	30%	30%	30%	30%

*The dimensions above have been customized based on specific user requirements. All of our MBBRs can be tailored to suit all kinds of aquaculture projects.

FILTRATION EQUIPMENTS

UV DISINFECTION SYSTEMS

ULTRAQUA UV DISINFECTION SYSTEMS

ULTRAQUA UV systems, our top preference in achieving successful results in aquaculture projects, offer **excellent solutions** for **effective disinfection** and **water quality management**. These advanced, **high-tech systems** are highly effective and reliable in

controlling microorganisms and maintaining the balance of water ecosystems.

You can achieve **high performance** and **efficiency** in your **aquaculture projects** with ULTRAQUA UV Disinfection Systems.



ADEC is the authorized distributor of Ultraqua's UV disinfection systems in Turkey.



Non-Corrosive PP Systems



NON-CORROSIVE PEHD Systems



ULTRABARRIER™ SS Systems



ULTRATRON™ Systems



Inclined Open Channel SS Systems



Open Channel PP Systems



MONORAY™ Systems



TOC VUV Systems



ULTRABARRIER™ PP Systems

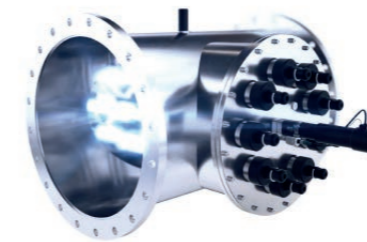

ULTRATRON™ Aop Systems

Maximum Capacities of PP Closed Vessels

UV System Model	UVT 95% 40 mj/cm ²	UVT 85% 40 mj/cm ²
MR1-75PP 1.5" BSP	4,5 m ³ /h	3,8 m ³ /h
MR2-75PP 3" BSP	11,5 m ³ /h	9 m ³ /h
MR3-75PP 3" BSP	18,5 m ³ /h	14,5 m ³ /h
MR4-75PP 3" BSP	28 m ³ /h	21,5 m ³ /h
MR1-220PP DN80	26 m ³ /h	20 m ³ /h
MR3-220PP DN150	120 m ³ /h	76 m ³ /h
MR4-220PP DN150	185 m ³ /h	110 m ³ /h
MR6-220PP DN150	285 m ³ /h	165 m ³ /h
MR8-220PP DN200	440 m ³ /h	240 m ³ /h
MR1-350PP DN100	41 m ³ /h	31 m ³ /h
MR3-350PP DN150	193 m ³ /h	120 m ³ /h
MR4-350PP DN150	295 m ³ /h	175 m ³ /h
MR6-350PP DN200	460 m ³ /h	270 m ³ /h
MR8-350PP DN250	710 m ³ /h	390 m ³ /h
MR12-350PP DN250	1100 m ³ /h	600 m ³ /h
MR16-350PP DN300	1600 m ³ /h	850 m ³ /h
MR18-350PP DN300	1800 m ³ /h	960 m ³ /h
MR20-350PP DN300	2000 m ³ /h	1050 m ³ /h



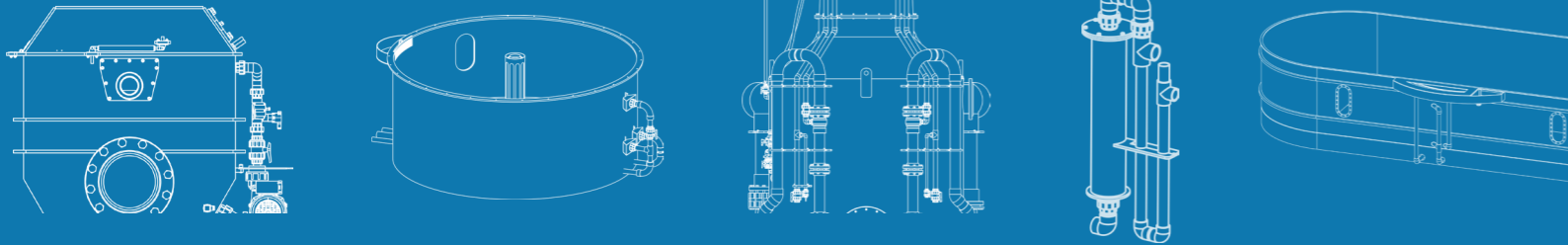

TANK UNITS

Tailored to meet **user requirements**, OCEANTECH™ **Tank Units** are renowned for their durability and longevity, making them an ideal choice for the aquaculture industry.

Available Tank Units

1. Broodstock Tanks
2. Egg Collectors
3. Incubation Tanks
4. Nursery Tanks
5. Holding Tanks
6. Rearing Tanks
7. Larvae Tanks
8. Decantation Tanks
9. Raceway Tanks
10. Live Fish Transport Tanks
11. Live Feed Tanks
(Artemia & Rotifer)
12. Fingerling Transport Tanks



Tank Units

User Benefits

- ✓ Durability, long lasting
- ✓ Expandable and customizable
- ✓ Coloured to your specifications
- ✓ Lightweighted
- ✓ For both fresh and saltwater applications

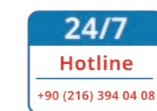

Broodstock Tanks



SIMONA

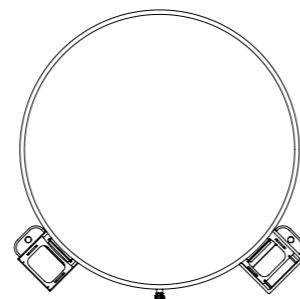

Top View



Side View

The OCEANTECH™ Broodstock Tanks, meticulously designed to **meet the unique requirements** of our customers. These tanks are **tailor-made** and crafted with utmost precision, ensuring the perfect environment for the **health** and **well-being** of the valuable broodstock.

Technical Specifications

MODEL	Ø 4130	Ø 4700	Ø 5000
Body Material	PE / PP	PE / PP	PE / PP
Footprint	4616 mm x 4216 mm	5266 mm x 4786 mm	5540 mm x 5140 mm
Diameter of Tank	Ø 4130 mm	Ø 4700 mm	Ø 5000 mm
Height	2000 mm	2000 mm	2000 mm
Dry Load (PP/PE)	432 kg	511 kg	572 kg
Volume	22,22 m ³	28,5 m ³	33,42 m ³
Compatibleness	RS-10 RS-10 PLUS AF-800 U	RS-10 RS-10 PLUS AF-800 U	RS-10 RS-10 PLUS AF-800 U

*The dimensions above have been customized based on specific user requirements. All of our aquaculture tanks can be tailored to suit all kinds of aquaculture projects.

Larvae Tanks



SIMONA

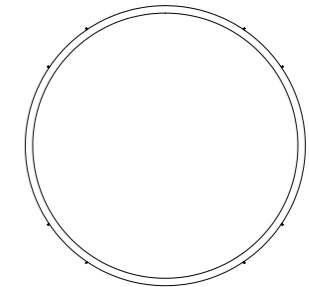

Top View

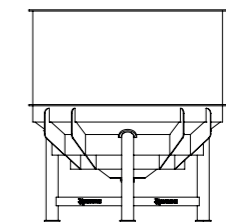

Side View

The OCEANTECH™ Larvae Tanks, crafted with a **tailor-made** approach to meet the distinct needs of our valued customers. These tanks are engineered to create an optimal environment for **nurturing delicate larvae**, providing them with the **ideal conditions** for growth and development.

Technical Specifications

MODEL	Ø 2200	Ø 3000	Ø 3500	Ø 3800
Body Material	PE / PP	PE / PP	PE / PP	PE / PP
Footprint	2300 mm x 2200 mm	3150 mm x 3150 mm	3610 mm x 3610 mm	4342 mm x 3912 mm
Diameter of Tank	Ø 2200 mm	Ø 3000 mm	Ø 3500 mm	Ø 3800 mm
Height	2462 mm	2215 mm	1500 mm	1500 mm
Dry Load (PP/PE)	160 kg	669 kg	271 kg	301 kg
Volume	5,36 m ³	10,7 m ³	11,18 m ³	13,25 m ³
Compatibleness	RS-10 RS-10 PLUS AF-800 U	RS-10 RS-10 PLUS AF-800 U	RS-10 RS-10 PLUS AF-800 U	RS-10 RS-10 PLUS AF-800 U

*The dimensions above have been customized based on specific user requirements. All of our aquaculture tanks can be tailored to suit all kinds of aquaculture projects.

Quarantine Tanks



SIMONA

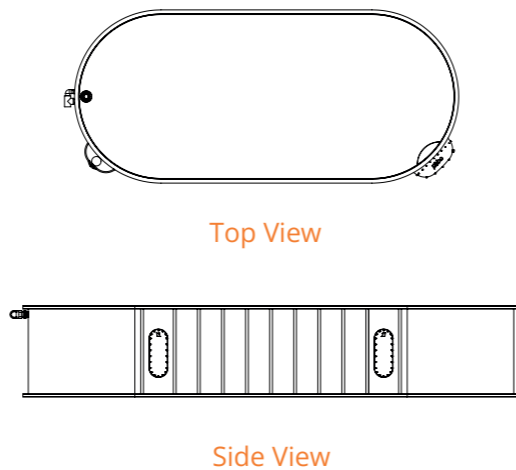

OCEANTECH™ Quarantine Tanks, specifically designed to meet the **unique requirements** and **preferences of our customers**. These tanks are ideal for use in aquaculture facilities due to their durable and **enduring construction**. Depending on the user's needs, they are available in both **elliptical** and **circular** shapes.



Quarantine Tank



SIMONA

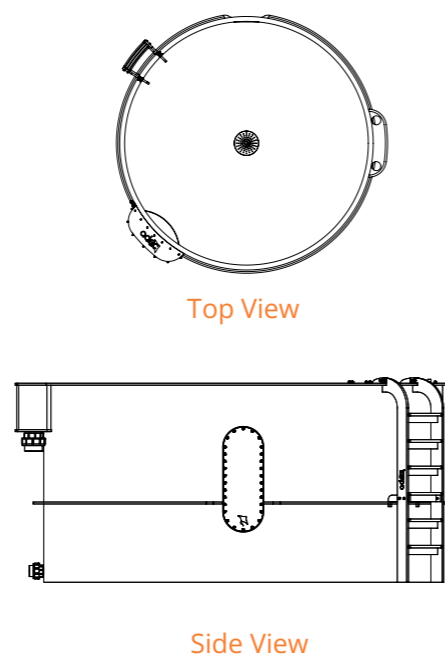

Technical Specifications					
	MODEL	Ø 2000	Ø 3000	Ø 5000	8000 Elliptical
Technical Specifications	Body Material	PE / PP	PE / PP	PE / PP	PE / PP
	Footprint	2311 mm x 2143 mm	3160 mm x 3500 mm	mm x mm	8200 mm x 3700 mm
	Diameter of Tank	Ø 2000 mm	Ø 3000 mm	Ø 5000 mm	-
	Height	1500 mm	1500 mm	mm	1500 mm
	Dry Load (PP/PE)	128 kg	256 kg	kg	1116 kg
	Volume	3.7 m ³	8.11 m ³	39.27 m ³	27.54 m ³
	Compatibleness	RS-10 RS-10 PLUS AF-800 U	RS-10 RS-10 PLUS AF-800 U	RS-10 RS-10 PLUS AF-800 U	RS-10 RS-10 PLUS AF-800 U

*The dimensions above have been customized based on specific user requirements. All of our aquaculture tanks can be tailored to suit all kinds of aquaculture projects.

Always Meet Your Aquatic Needs

Our tanks are manufactured with a focus on **durability**, ensuring a **long-lasting** solution for your aquatic environments. The **lightweight** and **strong design** makes installation and integration into existing projects or facilities easy and seamless.

Introducing our exclusive line of **custom-designed tanks**, tailored to **meet the unique needs** of our customers. Crafted with precision using **high-quality industrial plastic materials**, these tanks are the perfect choice for both **public aquariums** and **aquaculture facilities**.

Whether you require a tank for a public aquarium or an aquaculture facility, our systems are designed to **adapt effortlessly** to your specific requirements. With our expertise in customisation, we can create a tank that **perfectly suits** your needs, while providing a **safe** and **optimal habitat** for aquatic life.

- ✓ Durable
- ✓ Customizable
- ✓ Coloured to your specifications

- ✓ Lightweighted
- ✓ Strong
- ✓ High-quality material



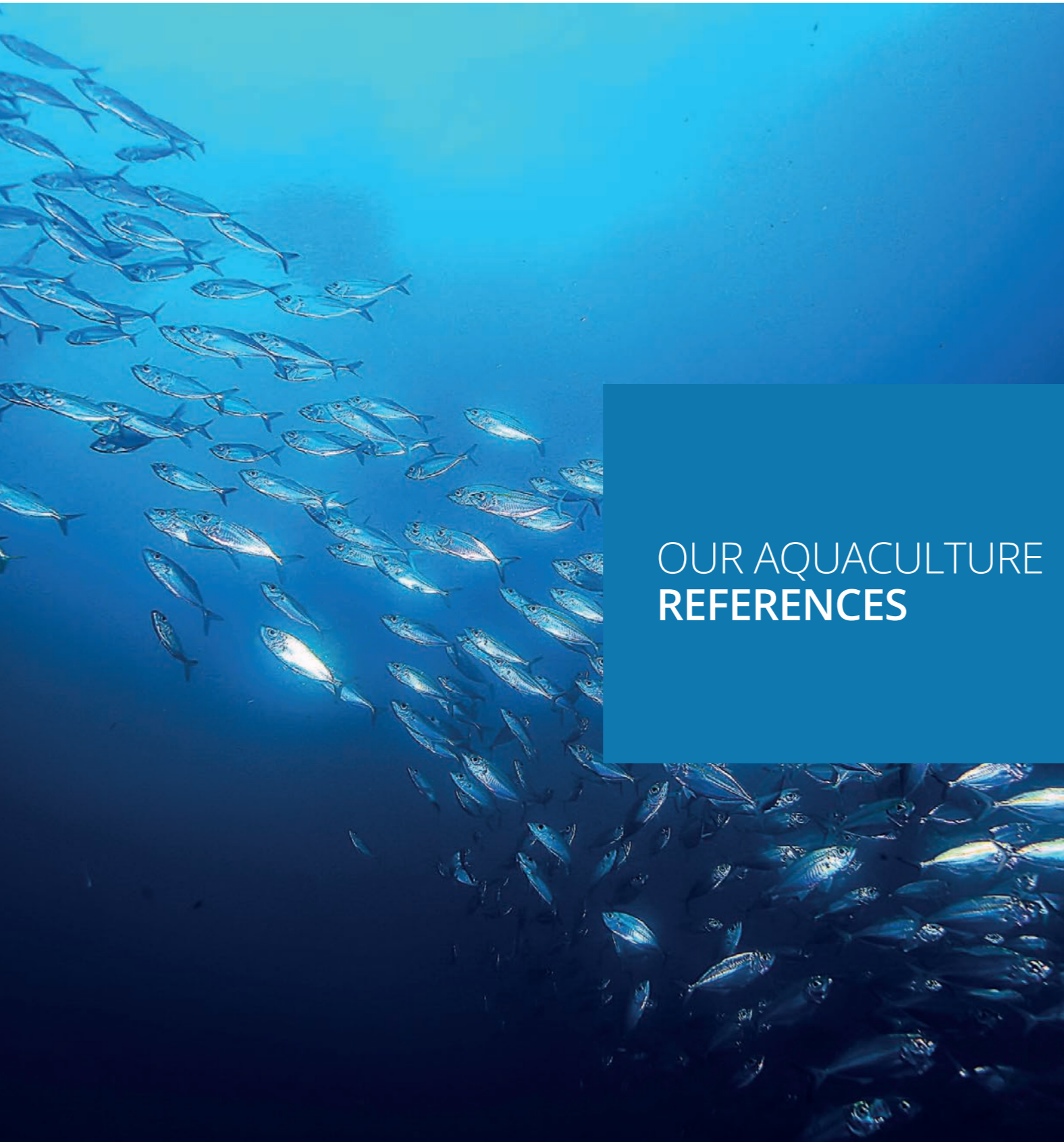

OUR AQUACULTURE REFERENCES

ADEC Aquaculture Facility

Mugla, Türkiye



The **ADEC Milas Aquaculture Facility** is the first and only combined **closed-circuit hatchery, nursery, and adaptation facility** in Türkiye. The production include a wide range of species including Trout & Sea Bass. The hatchery

consists of 2 sections – a hatchery section operated fully using **Recirculating Aquaculture System (RAS)** technology, and a ground pond section consisting of a combination of RAS and raceway systems.

- ✓ **Production Planning;** Annual Production planning for production of 39.000.000 fingerlings per year and Capacity planning
- ✓ **Design;** Architectural design of the facility according to defined capacity planning.
- ✓ **Engineering;** Complete Engineering of Filtration systems and related MEP. (P&ID, 2D and 3D filtration project)
- ✓ **Supply;** (Broodstock tanks, Larvae tanks, live feed culture tanks (Rotifer & Artemia), Incubators, Egg collectors, desaturators, Compact filtration skids for Broodstock tanks, Compact filtration skids for Larvae tanks and control/automation panels, PVC Pipes, valves and fittings, cable trays, cables and electrical termination items)
- ✓ **Installation & Commissioning;** (Broodstock tanks, Larvae tanks, live feed culture tanks (Rotifer & Artemia), Incubators, Egg collectors, desaturators, Compact filtration skids for Broodstock tanks, Compact filtration skids for Larvae tanks and control/automation panels and related onsite piping, cabling and electrical termination.
- ✓ **Construction & Project Management;** Onsite management of all onsite duties including excavation, laying foundations, Infrastructure, civil works (Core & Shell) and interior finishings.

SÜRSAN Aquaculture Facility

Mugla, Türkiye

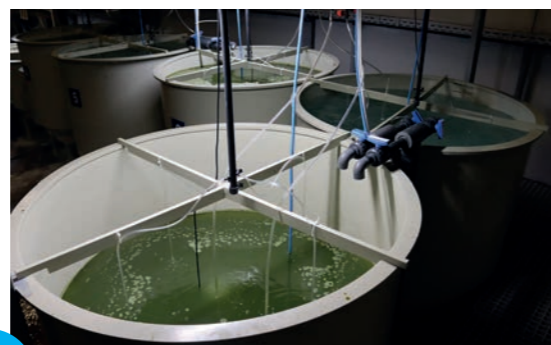

ADEC has supplied **aquaculture tanks** and **filtration equipments** to SÜRSAN, which always follows **innovations** and **high technology** in the aquaculture industry. With our

engineering service and specially developed product designs for Sürsan, we have succeeded in creating an unique project.

- ✓ **Supply;** (Broodstock tanks, Larvae tanks, Live feed culture tanks (Rotifer & Artemia), Incubators, Egg collectors, Desaturators, Compact filtration skids for Broodstock tanks, Compact filtration skids for Larvae tanks and Control/automation panels)
- ✓ **Installation & Commissioning;** (Broodstock tanks, Larvae tanks, Live feed culture tanks (Rotifer & Artemia), Incubators, Egg collectors, Desaturators, Compact filtration skids for Broodstock tanks and Compact filtration skids for Larvae tanks and Control/automation panels)

AGROMEY Aquaculture Facility

Mugla, Türkiye

Agromey

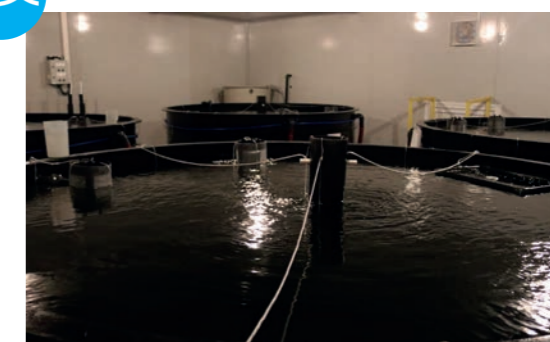

AGROMEY is one of the leading company in aquaculture sector with its accomplished integration of **fish farming**, **fish processing** and **packaging facilities** and **fish feed pro-**

duction facilities. To ensure the quality, Agromey has chosen ADEC's **high-tech RAS equipment** for their **1st Hatchery & Second Hatchery.**

- ✓ **Supply;** (Broodstock tanks, Larvae tanks, live feed culture tanks (Rotifer & Artemia), Incubators, Egg collectors, desaturators, Compact filtration skids for Broodstock tanks, Compact filtration skids for Larvae tanks and control/automation panels, PVC Pipes, valves and fittings, cable trays, cables and electrical termination items)
- ✓ **Installation & Commissioning;** (Broodstock tanks, Larvae tanks, live feed culture tanks (Rotifer & Artemia), Incubators, Egg collectors, desaturators, Compact filtration skids for Broodstock tanks, Compact filtration skids for Larvae tanks and control/automation panels and related onsite piping, cabling and electrical termination.

BALIKKONAK Aquaculture Facility

Mugla, Türkiye



For the **Balikkonak** Aquaculture Facility, we offered our expertise in **hatchery design** and **engineering, facility architectural**

design based on the provided **production planning**, and **hydraulic calculations** for the piping.

- ✓ **Supply;** (Broodstock tanks, Larvae tanks, live feed culture tanks (Rotifer & Artemia), Incubators, Egg collectors, desaturators, Compact filtration skids for Broodstock tanks, Compact filtration skids for Larvae tanks and control/automation panels, PVC Pipes, valves and fittings, cable trays, cables and electrical termination items)
- ✓ **Installation & Commissioning;** (Broodstock tanks, Larvae tanks, live feed culture tanks (Rotifer & Artemia), Incubators, Egg collectors, desaturators, Compact filtration skids for Broodstock tanks, Compact filtration skids for Larvae tanks and control/automation panels and related onsite piping, cabling and electrical termination.

TRABZON Chamber of Industry and Trade

Trabzon, Türkiye



For the **Turkish Salmon Closed Circuit Egg Production Facility** project in the Trabzon Chamber of Industry and Trade, we provided

Phase-1 services, which included the **design** and **engineering** of the **first RAS Salmon Hatchery**.

- ✓ **Production Planning;** Annual Production planning for production of 13.000.000 eggs and 7.800.000 smolt production per year and Capacity planning
- ✓ **Design;** Architectural design of the facility according to defined capacity planning.
- ✓ **Engineering;** Complete Engineering of Filtration systems and related MEP. (P&ID, 2D and 3D filtration Project)
- ✓ **Project and BOQ deliverables;** Complete set of architectural, Static, MEP Project deliveries and preparation of detailed BOQ and tendering documents.

KILIÇ Aquaculture Facility

Mugla, Türkiye



During their **29 years** aquaculture journey that started from Bodrum, **Kiliç** exported their fish to more than 60 countries. ADEC

has designed and engineered **RAS for nursery units** to achieve more effective filtration.

- ✓ **Design & Engineering;** Complete design and Engineering of RAS for Nursery units (P & ID, 2D and 3D filtration Project)
- ✓ **Supply;** RAS filtration unit and control/automation panels, PVC Pipes, valves and fittings, cable trays, cables and electrical termination items)
- ✓ **Installation & Commissioning;** RAS filtration unit and control/automation panels and related onsite piping, cabling and electrical termination.

ABALIOĞLU Aquaculture Facility

Mugla, Türkiye



The company which created a brand new field of activity in the integration of **Abalıoğlu** with the fish production realized under the **Lezita Balık** brand, produces sea bream, sea bass, granios and trout. Broodening Tanks, which are produced in line with the company's re-

quests, have many advantages in terms of production, such as being able to be made in various dimensions, **smooth inner surface, hygienic** and **antibacterial**.

- ✓ **Supply;** Broodstock tanks, RAS filtration unit and control/automation panels, PVC Pipes, valves and fittings, cable trays, cables and electrical termination items)
- ✓ **Installation & Commissioning;** Broodstock tanks, RAS filtration unit and control/automation panels and related onsite piping, cabling and electrical termination.

ASC Aquaculture Facility

Mugla, Türkiye

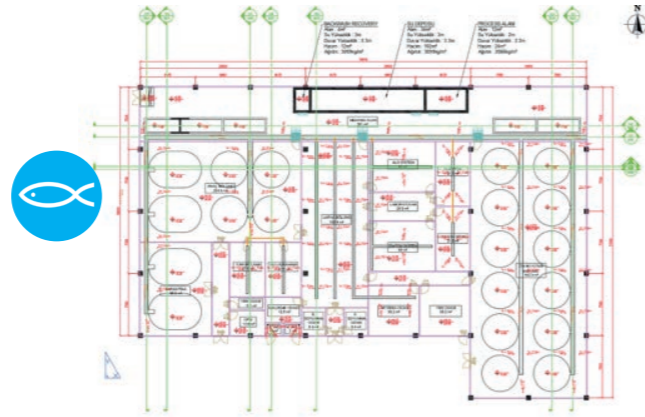

İDA GIDA SA

Canakkale, Türkiye



With the professional designs and engineering experience, ADEC has undertaken the project of **ASC** for the **traceability** of **shrimp**

production, which has recently become popular in Turkey but highly demanded in the world, especially during the hatch period.

- ✓ **Supply;** Larvae tanks, Compact Filtration skids filtration and control/automation panels, PVC Pipes, valves and fittings, cable trays, cables and electrical termination items)
- ✓ **Installation & Commissioning;** Larvae tanks, compact filtration skid and control/automation panels and related onsite piping, cabling and electrical termination.

İDA GIDA SA, founded in 1997 is specialized in hatchery production of gilt head bream, sea bass, maigre and turbot. We offer our services

to İDA, including the **production** and **commissioning** of Recirculating Aquaculture Systems (**RAS**).

- ✓ **Supply;** Compact Filtration skids filtration and control/automation panels, PVC Pipes, valves and fittings, cable trays, cables and electrical termination items)
- ✓ **Installation & Commissioning;** Compact filtration skid and control/automation panels and related onsite piping, cabling and electrical termination.

Istanbul University Faculty of Aquatic Science

Istanbul, Türkiye



With the aim of **contributing to scientific researches**, we have established the brand new **aquaculture facility** at Istanbul University Faculty of Aquatic Science. From tanks to filtration equipment, the facility is completed as a turnkey project.

- ✓ **Supply;** (Broodstock tanks, Larvae tanks, live feed culture tanks (Rotifer & Artemia), Incubators, Egg collectors, desaturators, Compact filtration skids for Broodstock tanks, Compact filtration skids for Larvae tanks and control/automation panels, PVC Pipes, valves and fittings, cable trays, cables and electrical termination items)
- ✓ **Installation & Commissioning;** (Broodstock tanks, Larvae tanks, live feed culture tanks (Rotifer & Artemia), Incubators, Egg collectors, desaturators, Compact filtration skids for Broodstock tanks, Compact filtration skids for Larvae tanks and control/automation panels and related onsite piping, cabling and electrical termination.

ALPHA AQUA A/S

Denmark

Alpha Aqua A/S was found in 2017 by two well-known Danish firms with lots of experience in the aquaculture industry. We supplied our **high-tech filtration** equipments to Alpha Aqua in order to increase the efficiency in their production.



- ✓ **Supply;** Protein skimmers, Ozone Generators & Control / Automation panels.

BIOMAR-RESEARCH FACILITY

Denmark

Since 1992, BioMar's in-house **research and development facilities** has steadily been expanding. ADEC supplied their **advanced filtration** equipments to BioMar-Research Facility in order to increase the efficiency in their production.



- ✓ **Supply;** Protein skimmers, Ozone Generators & Control / Automation panels.



We're here for you!

Our team is delighted to provide friendly and professional assistance throughout your aquatic project. Let us help you bring your vision to life and create extraordinary experiences.

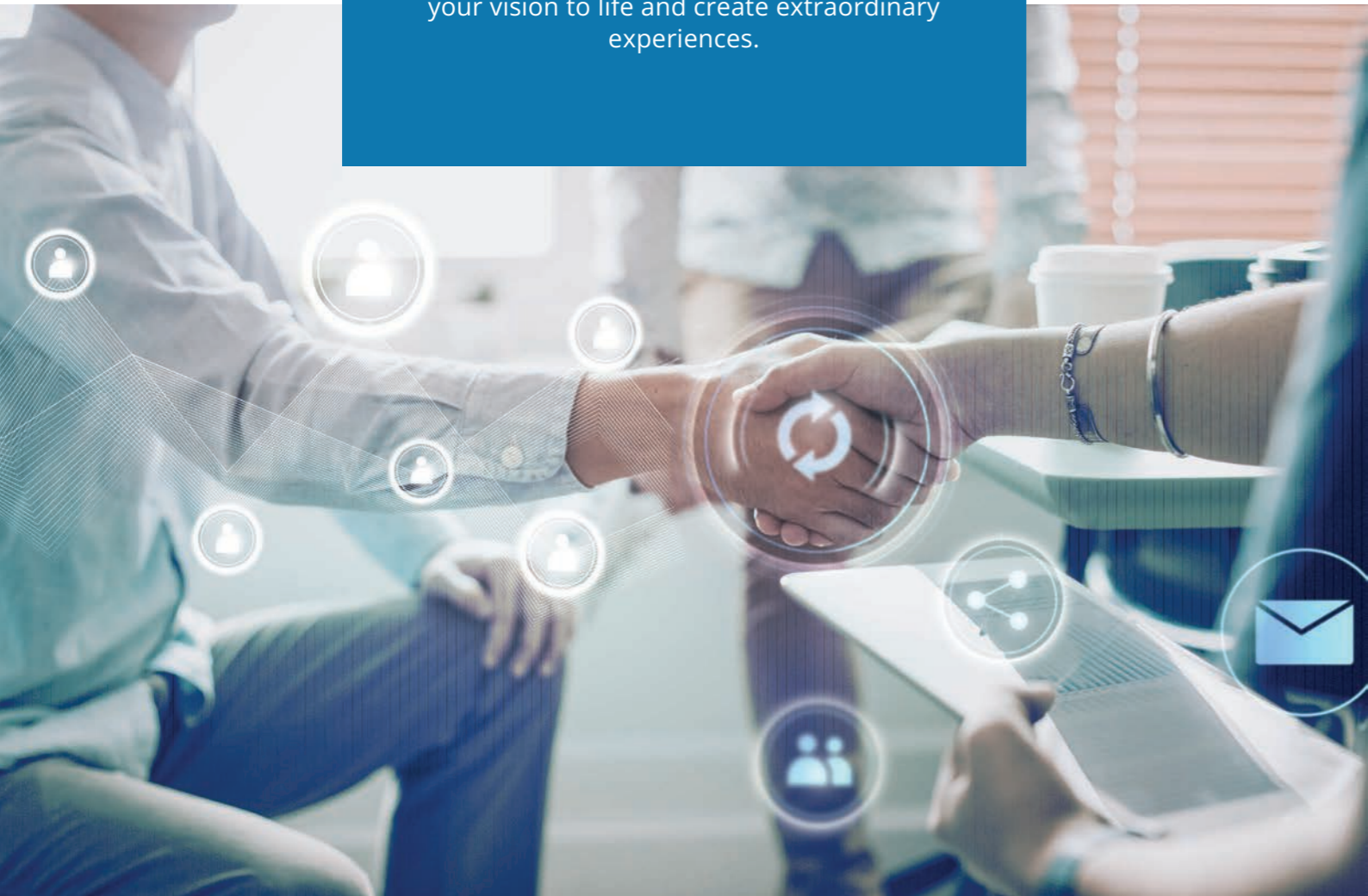

Take Action Today



Become a Client

As a leading industry provider, we offer tailored services to meet your unique aquatic needs. Whether you have a new project or want to enhance an existing one, we invite you to be a part of our success story. Contact us today and embark on an exciting journey as our valued partner.

Learn about new products and solutions for public aquarium and aquaculture industry in the ADEC e-mail newsletter.

Subscribe now!



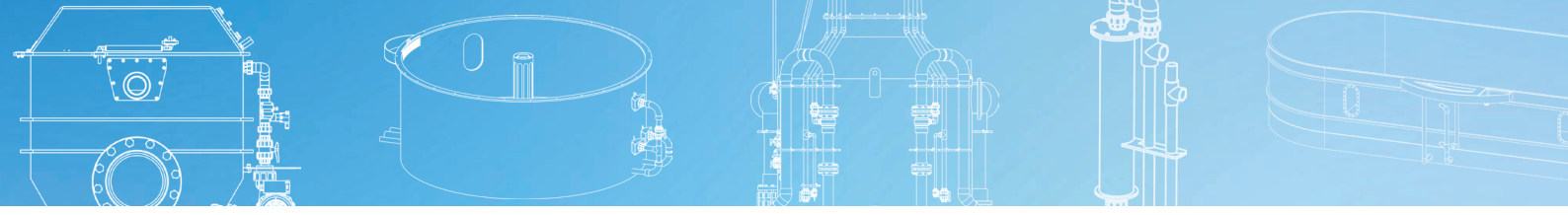

OCEANTECH

Aquatic Products & Technologies

HQ & Tuzla Factory
Deri Organize Sanayi Bölgesi
Apre Sokak No:3 Tuzla İstanbul Türkiye

Milas Factory & Aquaculture Facility
Avşar Mah. Zeytintümseği Mevkii
Ada:109 Milas Muğla Türkiye

+90 (216) 394 04 08

info@adec1ss.com



adec1ss.com

/adec_1ss

/adec1ss

/adec-1ss

adec
Aquatic Design Engineering Construction

